



# Certification Report

## HP Operations Orchestration 10.20

Issued by:

**Communications Security Establishment**

**Certification Body**

**Canadian Common Criteria Evaluation and Certification Scheme**

© Government of Canada, Communications Security Establishment, 2015

**Document number:** 383-4-321-CR  
**Version:** 1.0  
**Date:** 12 August 2015  
**Pagination:** i to iii, 1 to 10



**DISCLAIMER**

The Information Technology (IT) product identified in this certification report, and its associated certificate, has been evaluated at an approved evaluation facility – established under the Canadian Common Criteria Evaluation and Certification Scheme (CCS) – using the *Common Methodology for Information Technology Security Evaluation, Version 3.1 Revision 4*, for conformance to the *Common Criteria for Information Technology Security Evaluation, Version 3.1 Revision 4*. This certification report, and its associated certificate, applies only to the identified version and release of the product in its evaluated configuration. The evaluation has been conducted in accordance with the provisions of the CCS, and the conclusions of the evaluation facility in the evaluation report are consistent with the evidence adduced. This report, and its associated certificate, are not an endorsement of the IT product by the Communications Security Establishment, or any other organization that recognizes or gives effect to this report, and its associated certificate, and no warranty for the IT product by the Communications Security Establishment, or any other organization that recognizes or gives effect to this report, and its associated certificate, is either expressed or implied.

## FOREWORD

The Canadian Common Criteria Evaluation and Certification Scheme (CCS) provides a third-party evaluation service for determining the trustworthiness of Information Technology (IT) security products. Evaluations are performed by a commercial Common Criteria Evaluation Facility (CCEF) under the oversight of the CCS Certification Body, which is managed by the Communications Security Establishment.

A CCEF is a commercial facility that has been approved by the CCS Certification Body to perform Common Criteria evaluations; a significant requirement for such approval is accreditation to the requirements of *ISO/IEC 17025:2005, the General Requirements for the Competence of Testing and Calibration Laboratories*. Accreditation is performed under the Program for the Accreditation of Laboratories - Canada (PALCAN), administered by the Standards Council of Canada.

The CCEF that carried out this evaluation is CGI IT Security Evaluation & Test Facility.

By awarding a Common Criteria certificate, the CCS Certification Body asserts that the product complies with the security requirements specified in the associated security target. A security target is a requirements specification document that defines the scope of the evaluation activities. The consumer of certified IT products should review the security target, in addition to this certification report, in order to gain an understanding of any assumptions made during the evaluation, the IT product's intended environment, the evaluated security functionality, and the testing and analysis conducted by the CCEF.

This certification report is associated with the certificate of product evaluation dated 12 August 2015, and the security target identified in Section 4 of this report.

The certification report, certificate of product evaluation and security target are posted on the CCS Certified Products list (CPL) and the Common Criteria portal (the official website of the Common Criteria Project).

Reproduction of this report is authorized provided the report is reproduced in its entirety.

**TABLE OF CONTENTS**

<b>Disclaimer .....</b>	<b>i</b>
<b>Foreword.....</b>	<b>ii</b>
<b>Executive Summary .....</b>	<b>1</b>
<b>1 Identification of Target of Evaluation.....</b>	<b>2</b>
<b>2 TOE Description .....</b>	<b>2</b>
<b>3 Security Policy .....</b>	<b>3</b>
<b>4 Security Target.....</b>	<b>3</b>
<b>5 Common Criteria Conformance.....</b>	<b>3</b>
<b>6 Assumptions and Clarification of Scope .....</b>	<b>4</b>
6.1 SECURE USAGE ASSUMPTIONS.....	4
6.2 ENVIRONMENTAL ASSUMPTIONS .....	4
6.3 CLARIFICATION OF SCOPE.....	4
<b>7 Evaluated Configuration .....</b>	<b>5</b>
<b>8 Documentation .....</b>	<b>5</b>
<b>9 Evaluation Analysis Activities .....</b>	<b>6</b>
<b>10 ITS Product Testing.....</b>	<b>7</b>
10.1 ASSESSMENT OF DEVELOPER TESTS .....	7
10.2 INDEPENDENT FUNCTIONAL TESTING .....	7
10.3 INDEPENDENT PENETRATION TESTING.....	7
10.4 CONDUCT OF TESTING .....	8
10.5 TESTING RESULTS.....	8
<b>11 Results of the Evaluation.....</b>	<b>8</b>
<b>12 Evaluator Comments, Observations and Recommendations .....</b>	<b>8</b>
<b>13 Acronyms, Abbreviations and Initializations.....</b>	<b>9</b>
<b>14 References .....</b>	<b>10</b>

## Executive Summary

HP Operations Orchestration 10.20 (hereafter referred to as HP OO v10.20), from Hewlett Packard Enterprise Development L.P., is the Target of Evaluation. The results of this evaluation demonstrate that HP OO v10.20 meets the requirements of Evaluation Assurance Level (EAL) 2 augmented for the evaluated security functionality.

HP OO v10.20 is a process automation system. The TOE is a system designed for creating and executing actions in structured sequences (referred to as flows), which enable IT administrators to maintain, troubleshoot, repair, and provision IT resources. Using the TOE, organizations can automate the following tasks:

- Checking, diagnosing, and repairing networks, servers, services, software applications, and workstations;
- Checking clients, servers and virtual machines for needed software and updates, and if needed, automatically deploying the required software and updates; and
- Performing repetitive tasks, such as checking the status of websites, both internal and external.

CGI IT Security Evaluation & Test Facility is the CCEF that conducted the evaluation. This evaluation was completed on 12 August 2015 and was carried out in accordance with the rules of the Canadian Common Criteria Evaluation and Certification Scheme (CCS).

The scope of the evaluation is defined by the security target, which identifies assumptions made during the evaluation, the intended environment for HP OO v10.20, and the security functional/assurance requirements. Consumers are advised to verify that their operating environment is consistent with that specified in the security target, and to give due consideration to the comments, observations and recommendations in this certification report.

Communications Security Establishment, as the CCS Certification Body, declares that the HP OO v10.20 evaluation meets all the conditions of the *Arrangement on the Recognition of Common Criteria Certificates* and that the product will be listed on the CCS Certified Products list (CPL) and the Common Criteria portal (the official website of the Common Criteria Project).

# 1 Identification of Target of Evaluation

The Target of Evaluation (TOE) for this EAL 2+ evaluation is HP Operations Orchestration 10.20 (hereafter referred to as HP OO v10.20), from Hewlett Packard Enterprise Development L.P..

# 2 TOE Description

HP OO v10.20 is a process automation system. The TOE is a system designed for creating and executing actions in structured sequences (referred to as flows), which enable IT administrators to maintain, troubleshoot, repair, and provision IT resources. Using the TOE, organizations can automate the following tasks:

- Checking, diagnosing, and repairing networks, servers, services, software applications, and workstations;
- Checking clients, servers and virtual machines for needed software and updates, and if needed, automatically deploying the required software and updates; and
- Performing repetitive tasks, such as checking the status of websites, both internal and external.

A diagram of the HP OO v10.20 architecture is as follows:

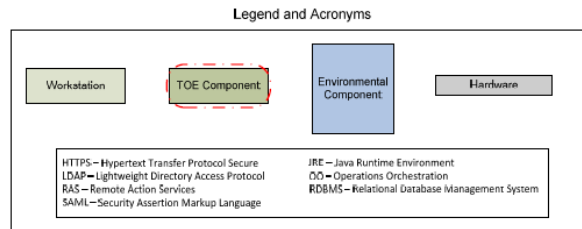
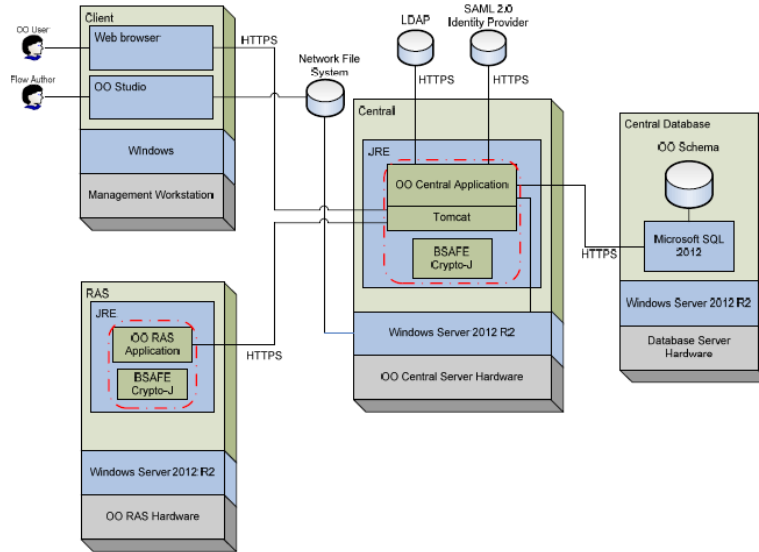

### 3 Security Policy

HP OO v10.20 implements a role-based access control policy to control administrative access to the system. In addition, HP OO v10.20 implements policies pertaining to the following security functional classes:

- Security Audit
- Cryptographic Support
- User Data Protection
- Identification and Authentication
- Security Management
- Protection of the TSF
- TOE Access
- Trusted Path/Channels

The following cryptographic modules were evaluated to the FIPS 140-2 standard:

Cryptographic Module	Certificate
RSA BSAFE® Crypto-J JSAFE and JCE Software Module (Software Version: 6.1or 6.1.1.0.1)	#2057

### 4 Security Target

The ST associated with this Certification Report is identified below:

Hewlett Packard Enterprise Development LP., Operations Orchestration v10.20, Security Target EAL2+ Version 0.14, August 11, 2015

### 5 Common Criteria Conformance

The evaluation was conducted using the *Common Methodology for Information Technology Security Evaluation, Version 3.1 Revision 4*, for conformance to the *Common Criteria for Information Technology Security Evaluation, Version 3.1 Revision 4*.

HP OO v10.20 is:

- a. EAL 2 augmented, containing all security assurance requirements listed, as well as the following:
  - ALC\_FLR.2 – Flaw Reporting Procedures
- b. Common Criteria Part 2 conformant, with security functional requirements based only upon functional components in Part 2;
- c. Common Criteria Part 3 conformant, with security assurance requirements based only upon assurance components in Part 3.

## 6 Assumptions and Clarification of Scope

Consumers of HP OO v10.20 should consider assumptions about usage and environmental settings as requirements for the product's installation and its operating environment. This will ensure the proper and secure operation of the TOE.

### 6.1 Secure Usage Assumptions

The following Secure Usage Assumptions are listed in the ST:

- The users who manage the TOE are non-hostile, appropriately trained, and follow all guidance.
- TOE users will use compatible applications in order to access the TOE.
- The users who manage the TOE environment are authorized to access the TOE environment.

### 6.2 Environmental Assumptions

The following Environmental Assumptions are listed in the ST:

- The TOE is installed on the appropriate operating system and runtime environment.
- The TOE and its environmental components are located within a controlled access facility.
- The TOE environment provides the network connectivity required to allow the TOE to perform secure routing and switching functions.
- The TOE environment provides the TOE with the necessary reliable timestamps.

### 6.3 Clarification of Scope

The HP OO Studio and HP OO Content functionalities are not included in the scope of the evaluation; see Section 1.5.3 of the ST. Users are provided with default templates that can be modified as the user requires.



## 7 Evaluated Configuration

The evaluated configuration for HP OO v10.20 comprises:

- The TOE installed on a server running Microsoft Windows Server 2012 R2
  - OO Central v10.20
  - OO RAS v10.20
  - RSA BSAFE Crypto-J JSAFE and JCE Software Module v6.1
  - Apache Tomcat server v7.0.47
- A GPC workstation running the following;
  - Internet browser
  - Java SE Runtime Environment (JRE) 7
- Microsoft SQL Server 2012
- An LDAP server in the environment for external LDAP authentication
- SAML 2.0 Identity Provider in the environment for SAML authentication

## 8 Documentation

The Hewlett Packard Enterprise Development L.P. documents provided to the consumer are as follows:

- a. Hewlett Packard Enterprise Development LP, Operations Orchestration v10.20, Guidance Documentation Supplement EAL2+ Version 0.7, July 23, 2015
- b. HP Operations Orchestration: Installation Guide, Software Version 10.20, November, 2014
- c. HP Operations Orchestration: Administration Guide, Software Version 10.20, November, 2014
- d. HP Operations Orchestration: Concepts Guide, Software Version 10.20, November, 2014
- e. HP Operations Orchestration: Central User Guide, Software Version 10.20, November, 2014
- f. HP Operations Orchestration: Application Program Interface (API) Guide, Software Version 10.20, November, 2014
- g. HP Operations Orchestration: Operations Orchestration Shell User Guide, Software Version 10.20, November, 2014
- h. HP Operations Orchestration: Studio Authoring Guide, Software Version 10.20, November, 2014
- i. HP Operations Orchestration: Hardening Guide, Software Version 10.20, November, 2014
- j. HP Operations Orchestration: System Requirements, Software Version 10.20, March, 2015

- k. HP Operations Orchestration: Architecture Guide, Software Version 10.20, November, 2014
- l. HP Operations Orchestration: Database Guide, Software Version 10.20, November, 2014.

## 9 Evaluation Analysis Activities

The evaluation analysis activities involved a structured evaluation of HP OO v10.20, including the following areas:

**Development:** The evaluators analyzed the HP OO v10.20 functional specification and design documentation; they determined that the design completely and accurately describes the TOE security functionality (TSF) interfaces, the TSF subsystems and how the TSF implements the security functional requirements (SFRs). The evaluators analyzed the HP OO v10.20 security architectural description and determined that the initialization process is secure, that the security functions are protected against tamper and bypass, and that security domains are maintained. The evaluators also independently verified that the correspondence mappings between the design documents are correct.

**Guidance Documents:** The evaluators examined the HP OO v10.20 preparative user guidance and operational user guidance and determined that it sufficiently and unambiguously describes how to securely transform the TOE into its evaluated configuration and how to use and administer the product. The evaluators examined and tested the preparative and operational guidance, and determined that they are complete and sufficiently detailed to result in a secure configuration.

**Life-cycle support:** An analysis of the HP OO v10.20 configuration management system and associated documentation was performed. The evaluators found that the HP OO v10.20 configuration items were clearly marked.

The evaluators examined the delivery documentation and determined that it described all of the procedures required to maintain the integrity of HP OO v10.20 during distribution to the consumer.

The evaluators reviewed the flaw remediation procedures used by developer for the HP OO v10.20. During a site visit, the evaluators also examined the evidence generated by adherence to the procedures. The evaluators concluded that the procedures are adequate to track and correct security flaws, and distribute the flaw information and corrections to consumers of the product

All these evaluation activities resulted in **PASS** verdicts.

## 10 ITS Product Testing

Testing consists of the following three steps: assessing developer tests, performing independent functional tests, and performing penetration tests.

### 10.1 Assessment of Developer Tests

The evaluators verified that the developer has met their testing responsibilities by examining their test evidence, and reviewing their test results, as documented in the ETR<sup>1</sup>.

The evaluators analyzed the developer's test coverage analysis and found it to be complete and accurate. The correspondence between the tests identified in the developer's test documentation and the functional specification was complete.

### 10.2 Independent Functional Testing

During this evaluation, the evaluator developed independent functional tests by examining design and guidance documentation.

All testing was planned and documented to a sufficient level of detail to allow repeatability of the testing procedures and results. Resulting from this test coverage approach is the following list of test goals:

- a. Repeat of Developer's Tests: The objective of this test goal is to repeat a subset of the developer's tests;
- b. Generation of audit records: The objective of this test goal is to confirm that the TOE can generate audit records for events not tested by the developer;
- c. User Privileges: The objective of this test goal is confirm that user privileges cannot be escalated;
- d. Permissions verification: The objective of this test goal is to verify that users without permissions are not capable of deploying content packs; and
- e. TOE management via REST API Calls: The objective of this test goal is to verify that the users are able to manage the TOE via REST API calls.

### 10.3 Independent Penetration Testing

Subsequent to the independent review of public domain vulnerability databases and all evaluation deliverables, limited independent evaluator penetration testing was conducted. The penetration tests focused on:

- a. Use of automated vulnerability scanning tools to discover potential network, platform and application layer vulnerabilities.

The independent penetration testing did not uncover any exploitable vulnerabilities in the intended operating environment.

---

<sup>1</sup> The ETR is a CCS document that contains information proprietary to the developer and/or the evaluator, and is not releasable for public review.

## 10.4 Conduct of Testing

HP OO v10.20 was subjected to a comprehensive suite of formally documented, independent functional and penetration tests. The detailed testing activities, including configurations, procedures, test cases, expected results and observed results are documented in a separate Test Results document.

## 10.5 Testing Results

The developer's tests and the independent functional tests yielded the expected results, providing assurance that HP OO v10.20 behaves as specified in its ST and functional specification.

## 11 Results of the Evaluation

This evaluation has provided the basis for a EAL 2+ level of assurance. The overall verdict for the evaluation is **PASS**. These results are supported by evidence in the ETR.

## 12 Evaluator Comments, Observations and Recommendations

Consumers of the HP should be familiar with the excluded functionality as detailed in section 1.5.3 "Product Physical/Logical Features and Functionality not included in the TOE" of the Security Target document. No claims are made against them and no vulnerability analysis was performed on them. Additionally, the users should consult the appropriate guidance documentation to place the TOE in the evaluated configuration during the installation process.

### 13 Acronyms, Abbreviations and Initializations

<u>Acronym/Abbreviation/Initialization</u>	<u>Description</u>
CCEF	Common Criteria Evaluation Facility
CCS	Canadian Common Criteria Evaluation and Certification Scheme
CPL	Certified Products list
CM	Configuration Management
EAL	Evaluation Assurance Level
ETR	Evaluation Technical Report
IT	Information Technology
ITSET	Information Technology Security Evaluation and Testing
PALCAN	Program for the Accreditation of Laboratories - Canada
REST API	Representational State Transfer Application Programming Interface
SAML	Security Assertion Markup Language
SFR	Security Functional Requirement
ST	Security Target
TOE	Target of Evaluation
TSF	TOE Security Function

## 14 References

This section lists all documentation used as source material for this report:

- a. CCS Publication #4, Technical Oversight, Version 1.8, October 2010.
- b. Common Criteria for Information Technology Security Evaluation, Version 3.1 Revision 4, September 2012.
- c. Common Methodology for Information Technology Security Evaluation, CEM, Version 3.1 Revision 4, September 2012.
- d. Hewlett Packard Enterprise Development LP., Operations Orchestration v10.20, Security Target EAL2+ Version 0.14, August 11, 2015
- e. Hewlett Packard Enterprise Development LP. Operations Orchestration 10.20 Common Criteria EAL2 Evaluation CGI IT Security Evaluation & Test Facility Evaluation Technical Report v1.0, August 12 2015.