

PUBLIC

**Common Criteria
Information Technology
Security Evaluation**

**Security Target Lite of
S3FS9CI
32-bit RISC Microcontroller
For S-SIM**

Version 1.0

4th June 2008



ELECTRONICS

REVISION HISTORY

UPDATES:

Version	Date	Modification
1.0	4 th June 2008	Creation

WRITERS:

Written by	Title
Bryant K.S. YI	Senior Engineer

CONTENTS

1	INTRODUCTION	4
1.1	SECURITY TARGET IDENTIFICATION.....	4
1.2	SECURITY TARGET OVERVIEW.....	4
1.3	CC CONFORMANCE & EVALUATION ASSURANCE LEVEL	5
2	TOE DESCRIPTION	6
2.1	PRODUCT DESCRIPTION	6
2.2	SMART CARD PRODUCT LIFE-CYCLE.....	8
2.3	TOE DEFINITION	11
2.4	TOE FEATURES	13
2.5	INTERFACES OF THE TOE	14
2.6	TOE INTENDED USAGE	14
3	TOE SECURITY ENVIRONMENT	15
3.1	DEFINITION OF ASSETS.....	15
3.2	ASSUMPTIONS.....	15
3.3	THREATS	16
3.4	ORGANIZATIONAL SECURITY POLICIES	19
4	SECURITY OBJECTIVES.....	20
4.1	SECURITY OBJECTIVES FOR THE TOE.....	20
4.2	SECURITY OBJECTIVES FOR THE ENVIRONMENT.....	23
5	IT SECURITY REQUIREMENTS	26
5.1	TOE SECURITY REQUIREMENTS	26
5.2	SECURITY REQUIREMENTS FOR THE ENVIRONMENT	37
6	TOE SUMMARY SPECIFICATION.....	44
6.1	LIST OF SECURITY FUNCTIONS	44
6.2	RELATIONSHIP BETWEEN SECURITY FUNCTIONS AND FUNCTIONAL REQUIREMENTS.....	48
6.3	ASSURANCE MEASURES.....	49
7	PP CLAIMS	50
7.1	PP REFERENCE	50
7.2	PP TAILORING.....	50
7.3	PP ADDITIONS.....	50
8	RATIONALE.....	51
8.1	SECURITY OBJECTIVES RATIONALE	51
8.2	SECURITY REQUIREMENTS RATIONALE.....	53
8.3	SECURITY REQUIREMENTS ARE MUTUALLY SUPPORTIVE AND INTERNALLY CONSISTENT	62
9	ANNEX	65

1 INTRODUCTION

2 This introductory chapter contains the following sections:

- 1.1 Security Target Identification
- 1.2 Security Target Overview
- 1.3 Common Criteria conformance & Evaluation Assurance Level

1.1 Security Target Identification

3 The Security Target version is 1.0 and dated 4th June 2008

4 The Security Target is conformant to the Smartcard IC Platform Protection Profile BSI-PP-0002 version 1.0, July 2001.

5 The Protection Profile and the Security Target are built on *Common Criteria version 2.3*.

- Title: Security Target of S3FS9CI 32-Bit RISC Microcontroller for S-SIM
- Target of Evaluation: S3FS9CI revision 2
- Provided by: Samsung Electronics Co., Ltd.
- Common Criteria version : *ISO/IEC 15408-2005(E) (CC V2.3) part 1 to 3*

1.2 Security Target Overview

6 This Security Target is the work of the Samsung Electronics Co., Ltd. TOE is smart card integrated circuit. The ST is “CC part 2 extended and CC part 3 conformant”. The TOE is to be evaluated with Common Criteria Version 2.3.

7 The assurance level for this ST is EAL4 augmented by the assurance component ADV_IMP.2 (Implementation representation), ALC_DVS.2 (Sufficiency of security measure), AVA_MSU.3 (Misuse) and AVA_VLA.4 (Highly resistant) without their dependencies.

8 The main objectives of this Security Target are:

- To describe the Target of Evaluation (TOE) as a functional product. This ST focuses on the development and use of integrated circuit.
- To describe the security environment of the TOE including the assets to be protected and the threats to be countered by the TOE and by the environment during the development and the operational phases of the card.
- To describe the security objectives of the TOE and its supporting environment in terms of integrity and confidentiality of application data and programs, protection of the TOE and associated documentation during the development phase.
- To specify the security requirements which include the TOE Security functional requirements and the TOE security assurance requirements.

1.3 CC Conformance & Evaluation Assurance Level

- 9 This security target conforms to *Common Criteria* version 2.3 (ISO15408) part 2 extended, part 3 conformant and conforms to the *Smartcard IC Platform Protection Profile BSI-PP-0002* version 1.0, July 2001. The assurance level is EAL4 augmented with components ADV_IMP2, ALC_DVS.2, AVA_MSU.3 and AVA_VLA.4. The minimum strength of the TOE security functions is Strength of Functions High (“SOF high”).

2 TOE DESCRIPTION

10 This chapter 2 contains the following sections:

- 2.1 Product Description
- 2.2 TOE Definition
- 2.3 TOE Features
- 2.4 Interface of the TOE
- 2.5 TOE intended usage

2.1 Product Description

- 11 The Target of Evaluation (TOE), the S3FS9CI is specially designed and packaged for secure chip card application using 0.13um process with supporting USB 2.0 Full speed, Inter-Chip USB, MMC 4.1 and massive NAND flash memory, as the name of S-SIM™. The S3FS9CI is built on the 16/32-bit SC100 RISC processor with 8kbytes TEST ROM, 32kbytes Mask ROM, 768kbytes NOR flash memory, 50kbytes static RAM and various type of large memory interfaces: NAND (SLC and MLC) and OneNAND flash interfaces. The ISO7816 interface is the only interface of this TOE.
- 12 The S3FS9CI has high-level security features such as DES/T-DES/AES accelerators, Montgomery Multiplier Engine (TORNADO™) for PKI, various detectors for abnormal situation detection, hardware logic for memory encryption/decryption and memory protection unit
- 13 The S3FS9CI single-chip CMOS micro-controller is designed and packaged specifically for "S-SIM" applications.
- 14 The main security features of the S3FS9CI integrated circuit are:
- Security sensors or detectors including High and Low Temperature detectors, High and Low Frequency detectors, High and Low Supply Voltage detectors, Supply Voltage Glitch detectors, Light detector and the Passivation Removing Detector
 - Active Shield against physical intrusive attacks
 - Memory protection unit (MPU)
 - Dedicated tamper-resistant design based on synthesizable glue logic and secure topology
 - Dedicated hardware mechanisms against side-channel attacks such as Internal Variable Clock, Random Current Generator, ROM, RAM and Nor FLASH scrambling mechanisms
 - Secure DES/T-DES and AES Symmetric Cryptography support
 - Secure Tornado™ coprocessor for RSA Asymmetric Cryptographic Support
 - On-the-fly CRC for detecting data contamination
 - A Random Number Generator (RNG)
 - The IC Dedicated Software includes:
 - A modular arithmetic library for RSA Asymmetric Cryptography support (optional)
 - A random number generator library meets the "standard" level of DCSSI requirement.

15 The main hardware blocks of the S3FS9CI Integrated Circuit are described in Figure 1 below:

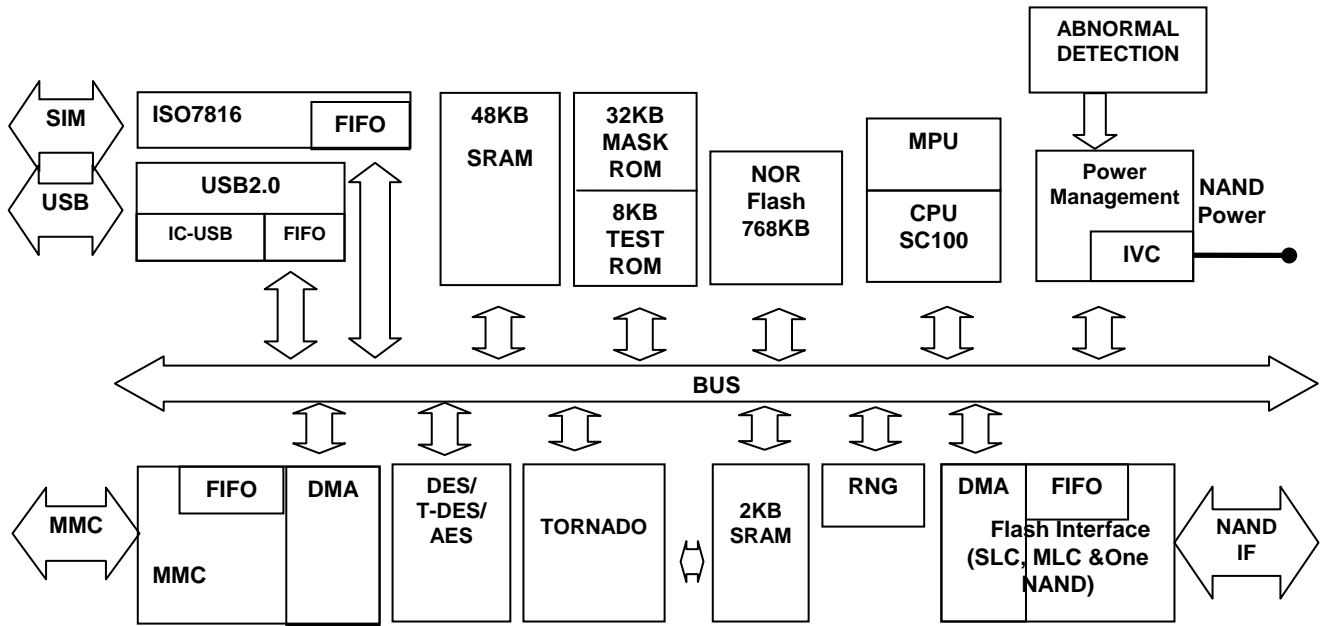

Figure2-1. S3FS9CI Block Diagram

16 Note that only the Triple DES algorithm belongs to the TOE, not the Single DES.

2.2 Smart Card Product Life-cycle

- 17 The Smart Card product life-cycle is decomposed into 7 phases, according to the “ Smart Card Integrated Circuit Protection Profile ”. (BSI-PP-0002-2001)

Phase 1	Smartcard embedded software development	The smart card embedded software developer is in charge of the smart card embedded software development and the specification of IC pre-personalisation requirements,
Phase 2	IC development	The IC designer designs the IC, develops IC dedicated software, provides information, software or tools to the smart card embedded software developer, and receives the smart card embedded software from the developer, through trusted delivery and verification procedures. From the IC design, IC dedicated software and smart card embedded software, he constructs the smart card IC database, necessary for the IC photomask fabrication,
Phase 3	IC manufacturing and wafer testing	The IC manufacturer is responsible for producing the IC through three main steps: IC manufacturing, IC wafer testing, and IC pre-personalisation,
Phase 4	IC packaging and testing	The IC packaging manufacturer is responsible for the IC packaging and testing,
Phase 5	Smartcard product finishing process	The smart card product manufacturer is responsible for the smart card product finishing process and testing,
Phase 6	Smartcard personalisation	The personaliser is responsible for the smart card personalisation and final tests. Other smart card embedded software may be loaded onto the chip at the personalisation process,
Phase 7	Smartcard end usage	The smart card issuer is responsible for the smart card product delivery to the smart card end-user , and the end of life process.

Table 2-1. Smart card product life-cycle phases

- 18 The limit of this Security Target corresponds to phase 2 and phase3, including the phase 1 delivery and verification procedures and the TOE delivery to the IC packaging manufacturer; phase 1, 4, 5, 6 and 7 are outside the scope of this ST.

19 The figure 2-2. describes the Smartcard product life-cycle.

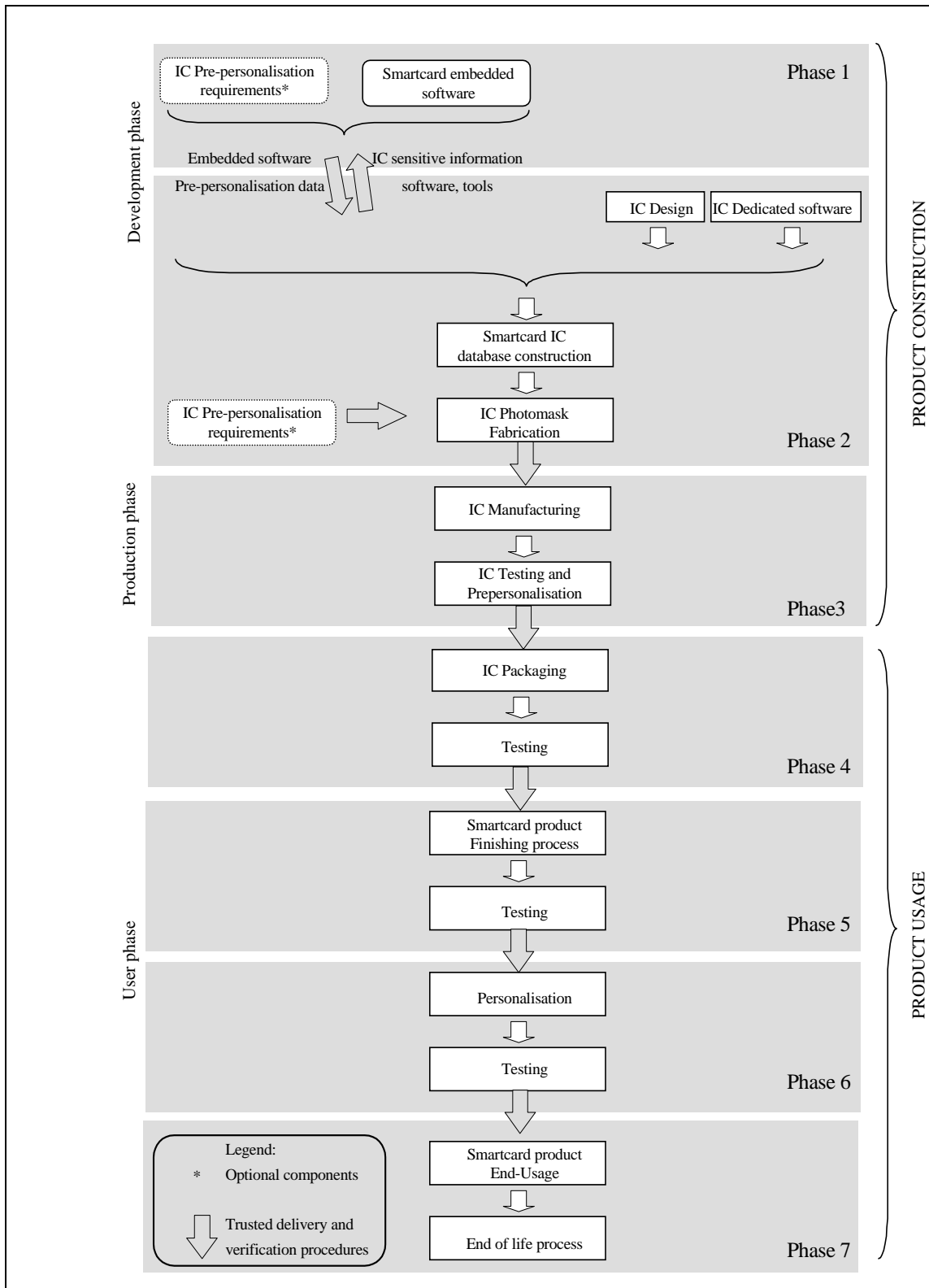

Figure 2-2. Smart card product life-cycle

20 Following table identifies the sites, which are within evaluation perimeter.

Phase	Description	Address for S3FS9CI
Phase 2	IC Development	C&M Development team Samsung Electronics Co., Ltd. San #24, Nongseo-dong, Giheung-gu, Yongin-City, Gyeonggi-Do, KOREA 449-711
	IC Photomask Fabrication	PKL 493-3 Sungsung-dong, Cheonan-City, Choongcheongnam-Do, Korea 330-300
Phase 3	IC Manufacturing	Line 5, Samsung Electronics Co., Ltd. San #24, Nongseo-dong, Giheung-gu, Yongin-City, Gyeonggi-Do, KOREA 449-711
	IC wafer Testing	Line 2, Samsung Electronics Co., Ltd. San #24, Nongseo-dong, Giheung-gu, Yongin-City, Gyeonggi-Do, KOREA 449-711

Table 2-2. Site identification within the evaluation perimeter

21 Procedures on the delivery process of the TOE must exist and be applied for every delivery within this phase or between phases. This includes any kind of delivery performed from phase 2 to 3, including:

- Intermediate delivery of the TOE or the TOE under construction within a phase
- Delivery of the TOE or the TOE under construction from one phase to the next.

22 These procedures shall be compliant with the assumptions [A.DLV].

23 The TOE controls following configurations:

TOE Configuration	Product Life Cycle	Authorized User (Role)
TEST Configuration	Phase 3	Test Administrator
USER Configuration	Phase 4 to 7	User

Table 2-3. TOE configurations

2.3 TOE Definition

24 The TOE consists of the following Hardware and Software:

2.3.1 TOE Hardware

- 768K bytes FLASH/48K bytes RAM/2K bytes Crypto. RAM/32K User ROM/8K Test ROM
- 32-bit Central Processing Unit (CPU)
- Internal Voltage Regulator (IVR)
- Detectors & Security Logic
- A random number generator (RNG)
- Memory Protection Unit (MPU)
- Triple DES cryptographic coprocessor with 112 or 168 bits key size
- Secure AES (Advanced Encryption Standard)
- TORNADO™ modular multiplier supporting up to 2048-bit RSA cryptography
- On-the-fly CRC for detecting data contamination
- ISO7816 interface
- Address & data buses
- Internal clock
- Timers
- RAM and FLASH scrambling mechanisms

2.3.2 TOE Software

25 The TOE software comprises the following components:

- Test ROM code that is used for testing the chip during production
- The TORNADO RSA secure cryptographic library v3.8S (optional)
TORNADO is Hardware coprocessor for high speed modular multiplications.
The TORNADO RSA Library v3.8S is a software library built on the TORNADO coprocessor that provides high level interface for RSA cryptographic algorithms.
The functions of the library included in the TOE are:

- TND_RSA_SigSTD_Secure (RSA signature generation with straightforward method)
- TND_RSA_SigCRT_Secure (RSA signature generation with CRT method)
- TND_RSA_SigCRT_Secure3 (RSA signature generation with CRT method)
- TND_RSA_Verify (RSA signature verification)
- RSA_Key_Generation (RSA key generation)

The library supports key sizes from 32 bits to 2048 bit by step of 2 bits. However, only key sizes from 1024 bits up to 2048 bits are within the scope of this evaluation.

The functions TND_RSA_SigSTD_Secure, TND_RSA_SigCRT_Secure and TND_RSA_SigCRT_Secure3 features some countermeasures against classical dedicated attacks such as SPA, DPA, high-order DPA and fault attacks.

- A random number generator library meets the “standard” level of DCSSI requirement

26 The TOE configuration is summarized in table 1 below:

Item Type	Item	Version	Form of delivery
Hardware	S3FS9CI 32-Bit RISC Microcontroller for S-SIM	2	Wafer
Software	Test ROM Code	1.0	Included in S3FS9CI Test ROM
Software (optional)	Secure Crypto. Library	3.8S	Software Library
Software	RNG Library	3.0	Software Library
Document	User's manual: S3FS9CI 32-bit CMOS Microcontroller for S-SIM	1.12	Softcopy
Document	Security Application Note - S3FS9CI	1.11	Softcopy
Document	RSA Application Note: Application Note - RSA Crypto Library with TORNADO version V3.8s	1.10	Softcopy
Document	RSA Crypto Library version V3.8s Design concept	1.7	Softcopy
Document	RNG Application Note	3.0	Softcopy
Document	S3FS9CI delivery specification	0.5	Softcopy
Document	Test Administrators Guidance	1.1	Softcopy

Table1. TOE Configuration

27 Note: The TOE can be delivered without the RSA crypto library. In this case the TOE does not provide the Additional Specific Security Functionality Rivest-Shamir-Adleman Cryptography.

2.4 TOE Features

CPU

- 32-bit SC100 core

Memory

- 32K-byte Program Memory (ROM)
- 8K- byte Test ROM
- 768K-byte Data/Program Memory (FLASH)
- 48K-byte Data/Program Memory (RAM)
- 2K-byte Crypto Memory (Crypto RAM)

Triple DES/AES

- Built-in hardware Triple DES/AES accelerator
- Circuit for resistance against SPA and DPA attacks

Tornado-II™

- Montgomery Modular multiplication accelerator
- Support various operand sizes

Abnormal Condition Detectors

- Abnormal Voltage/Frequency/Light/Temperature detectors
- Power glitch detector
- Active shield removal detector

Interrupts

- Normal or Fast interrupt modes (FIQ, IRQ)
- ISO7816 reset interrupt

Serial I/O Interface

- Hardware UART is implemented for T=0 and T=1 protocols
- Support asynchronous mode communication (conforms to ISO 7816 -3)

Reset

- Power-on reset circuit
- External reset/interrupt circuit (interrupt is default-enabled.)

Random Number Generator

- A random number generator fulfills the requirement of French metric.

Memory Protection Unit

- 8 separate regions using individual region base and region limit address registers

Memory Encryption for Security

- Dynamic data bus encryption: RAM, NOR Flash bank 0, 1, 2 area

On-the-fly CRC

- On-the-fly CRC for detecting data contamination

Timers

- 16-Bit Timer
- 32-Bit Timer
- 16-bit Watchdog Timer

Clock Sources

- External clock: 1 MHz–10 MHz
- Internal clock: 4MHz–26MHz (non-divided)

Operating Voltage Range

- 1.62 V – 5.5 V

Operating Temperature

- - 25°C to 85°C

2.5 Interfaces of the TOE

- The physical interface of the TOE with the external environment is the entire surface of the IC
- The electrical interface of the TOE with the external environment is made of the chip's pads including the Vdd, RESET, CLK, GND, and I/O.
- The data interface of the TOE is made of the Contact I/O pads
- The software interface of the TOE with the hardware consists of Special Function Registers (SFR) and CPU instructions.
- The RSA interface of the TOE is defined by the RSA library interface (optional).

2.6 TOE Intended Usage

28 The TOE is dedicated to applications such as:

- Banking and finance applications for credit or debit cards, electronic purse (stored value cards) and electronic commerce.
- Network based transaction processing such a mobile phones (GSM SIM cards), pay TV (subscriber and pay-per-view cards), communication highways (Internet access and transaction processing).
- Transport and ticketing applications (access control cards).
- Governmental cards (ID cards, health cards, driving licenses).
- Multimedia applications and Digital Right Management protection.

3 TOE SECURITY ENVIRONMENT

29 This chapter 3 contains the following sections:

- 3.1 Definition of Assets
- 3.2 Assumptions
- 3.3 Threats
- 3.4 Organizational Security Policies

3.1 Definition of Assets

30 The primary assets to be protected are

- User's Data stored in the TOE memories (confidentiality and integrity)
- Smartcard Embedded Software for (confidentiality and integrity)
- Correct operation of the TOE (integrity)

31 Other primary assets are

- Random numbers generated by the TOE (confidentiality and integrity)

32 Other secondary assets are

- logical design data,
- physical design data,
- IC Dedicated Software, Initialization Data, Pre-personalization Data, TSF data
- specific development aids,
- test and characterization related data,
- material for software development support, and
- photomasks and products in any form

3.2 Assumptions

33 The following assumptions apply in this Security Target.

A.Process-Card Protection during Packaging, Finishing and Personalisation

It is assumed that security procedures are used after delivery of the TOE by the TOE Manufacturer up to delivery to the end-user to maintain confidentiality and integrity of the TOE and of its manufacturing and test data (to prevent any possible copy, modification, retention, theft or unauthorised use).

A.Plat-Appl Usage of Hardware Platform

The Smartcard Embedded Software is designed so that the requirements from the following documents are met:

- (i) S3FS9CI User's manual

- (ii) S3FS9CI Security application Note
- (iii) TOE application notes, and
- (iv) Results from TOE evaluation reports relevant for the Smartcard Embedded Software.

A.Resp-Appl

Treatment of User Data

All User Data are owned by Smartcard Embedded Software. Therefore, it must be assumed that security relevant User Data (especially cryptographic keys) are treated by the Smartcard Embedded Software as defined for the specific application context.

- 34 The developer of the Smartcard Embedded Software must ensure the appropriate “Usage of Key-dependent Functions (A.Key-Function)” while developing this software in Phase 1 as specified below.

A.Key-Function

Usage of Key-dependent Functions

Key-dependent functions (if any) shall be implemented in the Smartcard Embedded Software in a way that they are not susceptible to leakage attacks (as described under T.Leak-Inherent and T.Leak-Forced).

Note that here the routines which may compromise keys when being executed are part of the Smartcard Embedded Software. In contrast to this the threats T.Leak-Inherent and T.Leak-Forced address (i) the cryptographic routines which are part of the TOE and (ii) the processing of User Data including cryptographic keys.

3.3 Threats

- 35 According to the *Protection Profile BSI-PP-0002*, section 3.3 there are the following high-level security concerns:

SC1 Manipulation of User Data and of the Smartcard Embedded Software (while being executed/processed and while being stored in the TOE’s memories)

SC2 Disclosure of User Data and of the Smartcard Embedded Software (while being processed and while being stored in the TOE’s memories).

SC3 Deficiency of random numbers.

3.3.1 Standard Threats (referring to SC1 and SC2)

- 36 The TOE shall avert the threat “Inherent Information Leakage (T.Leak-Inherent)” as specified below.

T.Leak-Inherent

Inherent Information Leakage

An attacker may exploit information which is leaked from the TOE during usage of the Smartcard in order to disclose confidential data (User Data or TSF data).

No direct contact with the Smartcard internals is required here. Leakage may occur through emanations, variations in power consumption, I/O characteristics, clock frequency, or by changes in processing time requirements. One example is the Differential Power Analysis (DPA).

37 The TOE shall avert the threat “Physical Probing (T.Phys-Probing)” as specified below.

T.Phys-Probing Physical Probing

An attacker may perform physical probing of the TOE in order (i) to disclose User Data, (ii) to disclose/reconstruct the Smartcard Embedded Software or (iii) to disclose other critical operational information especially TSF data.

Physical probing requires direct interaction with the Smartcard Integrated Circuit internals. Techniques commonly employed in IC failure analysis and IC reverse engineering efforts may be used. Before that hardware security mechanisms and layout characteristics need to be identified. Determination of software design including treatment of User Data may also be a pre-requisite.

38 The TOE shall avert the threat “Malfunction due to Environmental Stress (T.Malfunction)” as specified below.

T.Malfunction Malfunction due to Environmental Stress

An attacker may cause a malfunction of TSF or of the Smartcard Embedded Software by applying environmental stress in order to (i) deactivate or modify security features or functions of the TOE or (ii) deactivate or modify security functions of the Smartcard Embedded Software. This may be achieved by operating the Smartcard outside the normal operating conditions. To exploit this an attacker needs information about the functional operation.

39 The TOE shall avert the threat “Physical Manipulation (T.Phys-Manipulation)” as specified below.

T.Phys-Manipulation Physical Manipulation

An attacker may physically modify the Smartcard in order to (i) modify security features or functions of the TOE, (ii) modify security functions of the Smartcard Embedded Software or (iii) to modify User Data.

The modification may be achieved through techniques commonly employed in IC failure analysis and IC reverse engineering efforts. The modification may result in the deactivation of a security function. Before that hardware security mechanisms and layout characteristics need to be identified. Determination of software design including treatment of User Data may also be a pre-requisite. Changes of circuitry or data can be permanent or temporary.

In contrast to malfunctions (refer to T.Malfunction) the attacker requires to gather significant knowledge about the TOE’s internal construction.

40 The TOE shall avert the threat “Forced Information Leakage (T.Leak-Forced)” as specified below:

T.Leak-Forced Forced Information Leakage

An attacker may exploit information which is leaked from the TOE during usage of the Smartcard in order to disclose confidential data (User Data or TSF data) even if the information leakage is not inherent but caused by the attacker.

This threat pertains to attacks where methods described in “Malfunction due to Environmental Stress” (refer to T.Malfunction) and/or “Physical Manipulation” (refer to T.Phys-Manipulation) are used to cause leakage from signals which normally do not contain significant information about secrets.

41 The TOE shall avert the threat “Abuse of Functionality (T.Abuse-Func)” as specified below.

T.Abuse-Func Abuse of Functionality

An attacker may use functions of the TOE which may not be used after TOE Delivery in order to (i) disclose or manipulate User Data, (ii) to manipulate (explore, bypass, deactivate or change) security features or functions of the TOE or of the Smartcard Embedded Software or (iii) to enable an attack.

3.3.2 Threats related to Specific Functionality (referring to SC3)

42 The TOE shall avert the threat “Deficiency of Random Numbers (T.RND)” as specified below.

T.RND Deficiency of Random Numbers

An attacker may predict or obtain information about random numbers generated by the TOE for instance because of a lack of entropy of the random numbers provided.

An attacker may gather information about the produced random numbers which might be a problem because they may be used for instance to generate cryptographic keys.

Here the attacker is expected to take advantage of statistical properties of the random numbers generated by the TOE without specific knowledge about the TOE’s generator. Malfunctions or premature ageing are also considered which may assist in getting information about random numbers.

3.3.3 Threats related to additional TOE Specific Functionality

43 The TOE shall avert the additional threat “Memory Access Violation (T.Mem-Access)” as specified below.

T.Mem-Access Memory Access Violation

Parts of the Smartcard Embedded Software may cause security violations by accidentally or deliberately accessing restricted data (which may include code). Any restrictions are defined by the security policy of the specific application context and must be implemented by the Smartcard Embedded Software.

3.4 Organizational Security Policies

- 44 The IC Developer / Manufacturer must apply the policy “Protection during TOE Development and Production (P.Process-TOE)” as specified below.

P.Process-TOE Protection during TOE Development and Production

The TOE Manufacturer must ensure that the development and production of the Smartcard Integrated Circuit (Phase 2 up to TOE Delivery, refer to Section 2.1) is secure so that no information is unintentionally made available for the operational phase of the TOE. For example, the confidentiality and integrity of design information and test data shall be guaranteed; access to samples, development tools and other material shall be restricted to authorized persons only; scrap will be destroyed etc. This not only pertains to the TOE but also to all information and material exchanged with the developer of the Smartcard Embedded Software and therefore especially to the Smartcard Embedded Software itself. This includes the delivery (exchange) procedures for Phase 1 and the Phases after TOE Delivery as far as they can be controlled by the TOE Manufacturer.

An accurate identification must be established for the TOE. This requires that each instantiation of the TOE carries this unique identification.

- 45 The TOE provides specific security functionality which can be used by the Smartcard Embedded Software. In the following specific security functionality is listed which is not derived from threats identified for the TOE’s environment because it can only be decided in the context of the smartcard application, against which threats the Smartcard Embedded Software will use the specific security functionality.

- 46 The IC Developer / Manufacturer must apply the policy “Additional Specific Security Functionality (P.Add-Functions)” as specified below.

P.Add-Functions Additional Specific Security Functionality

The TOE shall provide the following specific security functionality to the Smartcard Embedded Software:

- Triple Data Encryption Standard (3DES)
- Rivest-Shamir-Adleman (RSA) public key asymmetric cryptography (optional)
- Advanced Encryption Standard (AES)
- On-the-fly CRC

4 SECURITY OBJECTIVES

47 This chapter Security Objectives contains the following sections:

4.1 Security Objectives for the TOE

4.2 Security Objectives for Environment

4.1 Security objectives for the TOE

48 According to the Protection Profile[BSI-PP-0002] there are the following standard high-level security goals:

SG1 maintain the integrity of User Data and of the Smartcard Embedded Software (when being executed/processed and when being stored in the TOE's memories)

SG2 maintain the confidentiality of User Data and of the Smartcard Embedded Software (when being processed and when being stored in the TOE's memories).

SG3 provide random numbers.

49 These standard high-level security goals are refined below by defining security objectives as required by the *Common Criteria*. Note that the integrity of the TOE is a mean to reach these objectives.

4.1.1 Standard Security Objectives (referring to SG1 and SG2)

50 The TOE shall provide "Protection against Inherent Information Leakage (O.Leak-Inherent)" as specified below.

O.Leak-Inherent Protection against Inherent Information Leakage

The TOE must provide protection against disclosure of confidential data (User Data or TSF data) stored and/or processed in the Smartcard IC

- by measurement and analysis of the shape and amplitude of signals (for example on the power, clock, or I/O lines) and
- by measurement and analysis of the time between events found by measuring signals (for instance on the power, clock, or I/O lines).

This objective pertains to measurements with subsequent complex signal processing whereas O.Phys-Probing is about direct measurements on elements on the chip surface. Details correspond to an analysis of attack scenarios which is not given here.

51 The TOE shall provide "Protection against Physical Probing (O.Phys-Probing)" as specified below.

O.Phys-Probing Protection against Physical Probing

The TOE must provide protection against disclosure of User Data, against the disclosure/reconstruction of the Smartcard Embedded Software or against the disclosure of other critical operational information. This includes protection against

- measuring through galvanic contacts which is direct physical probing on the chips surface except on pads being bonded (using standard tools for measuring voltage and current) or
- measuring not using galvanic contacts but other types of physical interaction between charges (using tools used in solid-state physics research and IC failure analysis)

with a prior

- reverse-engineering to understand the design and its properties and functions.

The TOE must be designed and fabricated so that it requires a high combination of complex equipment, knowledge, skill, and time to be able to derive detailed design information or other information which could be used to compromise security through such a physical attack.

52 The TOE shall provide “Protection against Malfunctions (O.Malfunction)” as specified below.

O.Malfunction Protection against Malfunctions

The TOE must ensure its correct operation.

The TOE must prevent its operation outside the normal operating conditions where reliability and secure operation has not been proven or tested. This is to prevent errors. The environmental conditions may include voltage, clock frequency, temperature, or external energy fields.

Remark: A malfunction of the TOE may also be caused using a direct interaction with elements on the chip surface. This is considered as being a manipulation (refer to the objective O.Phys-Manipulation) provided that detailed knowledge about the TOE’s internal construction is required and the attack is performed in a controlled manner.

53 The TOE shall provide “Protection against Physical Manipulation (O.Phys-Manipulation)” as specified below.

O.Phys-Manipulation Protection against Physical Manipulation

The TOE must provide protection against manipulation of the TOE (including its software and TSF data), the Smartcard Embedded Software and the User Data. This includes protection against

- reverse-engineering (understanding the design and its properties and functions),
- manipulation of the hardware and any data, as well as
- controlled manipulation of memory contents (User Data).

The TOE must be designed and fabricated so that it requires a high combination of complex equipment, knowledge, skill, and time to be able to derive detailed design information or other information which could be used to compromise security through such a physical attack.

54 The TOE shall provide "Protection against Forced Information Leakage (O.Leak-Forced)" as specified below:

O.Leak-Forced Protection against Forced Information Leakage

The Smartcard must be protected against disclosure of confidential data (User Data or TSF data) processed in the Card (using methods as described under O.Leak-Inherent) even if the information leakage is not inherent but caused by the attacker

- by forcing a malfunction (refer to "Protection against Malfunction due to Environmental Stress (O.Malfunction)" and/or
- by a physical manipulation (refer to "Protection against Physical Manipulation (O.Phys-Manipulation)").

If this is not the case, signals which normally do not contain significant information about secrets could become an information channel for a leakage attack.

55 The TOE shall provide "Protection against Abuse of Functionality (O.Abuse-Func)" as specified below.

O.Abuse-Func Protection against Abuse of Functionality

The TOE must prevent that functions of the TOE which may not be used after TOE Delivery can be abused in order (i) to disclose critical User Data, (ii) to manipulate critical User Data of the Smartcard Embedded Software, (iii) to manipulate Soft-coded Smartcard Embedded Software or (iv) bypass, deactivate, change or explore security features or functions of the TOE. Details depend, for instance, on the capabilities of the Test Features provided by the IC Dedicated Test Software which are not specified here.

56 The TOE shall provide "TOE Identification (O.Identification)" as specified below:

O.Identification TOE Identification

The TOE must provide means to store Initialisation Data and Pre-personalisation Data in its non-volatile memory. The Initialisation Data (or parts of them) are used for TOE identification.

4.1.2 Security Objectives related to Specific Functionality (referring to SG3)

57 The TOE shall provide "Random Numbers (O.RND)" as specified below.

O.RND Random Numbers

The TOE will ensure the cryptographic quality of random number generation. For instance random numbers shall not be predictable and shall have sufficient entropy.

The TOE will ensure that no information about the produced random numbers is available to an attacker since they might be used for instance to generate cryptographic keys.

4.1.3 Security Objectives for Added Function

58 The TOE shall provide “Additional Specific Security Functionality (O.Add-Functions)” as specified below.

O.Add-Functions Additional Specific Security Functionality

The TOE must provide the following specific security functionality to the Smartcard Embedded Software:

- Triple Data Encryption Standard (3DES)
- Advanced Encryption Standard (AES)
- Rivest-Shamir-Adleman (RSA) public key asymmetric cryptography (optional)
- On-the-fly CRC

59 The TOE shall provide “Area based Memory Access Control (O.Mem-Access)” as specified below.

O.Mem-Access Area based Memory Access Control

The TOE must provide the Smartcard Embedded Software with the capability to define restricted access memory areas. The TOE must then enforce the partitioning of such memory areas so that access of software to memory areas is controlled as required, for example, in a multi-application environment.

4.2 Security objectives for the Environment

4.2.1 Phase 1

60 The Smartcard Embedded Software shall provide “Usage of Hardware Platform (OE.Plat-Appl)” as specified below.

OE.Plat-Appl Usage of Hardware Platform

To ensure that the TOE is used in a secure manner the Smartcard Embedded Software shall be designed so that the requirements from the following documents are met:

- (i) S3FS9CI User’s manual
- (ii) S3FS9CI Security Application Note
- (iii) TOE application notes, and
- (iv) Results from the TOE evaluation reports relevant for the Smartcard Embedded Software.

61 The Smartcard Embedded Software shall provide “Treatment of User Data (OE.Resp-Appl)” as specified below.

OE.Resp-Appl Treatment of User Data

Security relevant User Data (especially cryptographic keys) are treated by the Smartcard Embedded Software as required by the security needs of the specific application context.

For example the Smartcard Embedded Software will not disclose security relevant user data to unauthorised users or processes when communicating with a terminal.

4.2.2 Phase 2 up to TOE Delivery

- 62 The TOE Manufacturer shall ensure the “Protection during TOE Development and Production (OE.Process-TOE)” as specified below.

OE.Process-TOE Protection during TOE Development and Production

The TOE Manufacturer must ensure that the development and production of the Smartcard Integrated Circuit (Phases 2 and 3 up to TOE Delivery, refer to Section 2.1) is secure so that no information is unintentionally made available for the operational phase of the TOE. For example, the confidentiality and integrity of design information and test data must be guaranteed, access to samples, development tools and other material must be restricted to authorised persons only, scrap must be destroyed. This not only pertains to the TOE but also to all information and material exchanged with the developer of the Smartcard Embedded Software and therefore especially to the Smartcard Embedded Software itself. This includes the delivery (exchange) procedures for Phase 1 and the Phases after TOE Delivery as far as they can be controlled by the TOE Manufacturer.

An accurate identification must be established for the TOE. This requires that each instantiation of the TOE carries this unique identification. In order to make this practical, electronic identification shall be possible.

4.2.3 TOE Delivery up to the end of Phase 6

- 63 Appropriate “Protection during Packaging, Finishing and Personalisation (OE.Process-Card)” must be ensured after TOE Delivery up to the end of Phases 6, as well as during the delivery to Phase 7 as specified below.

OE.Process-Card Protection during Packaging, Finishing and Personalisation

Security procedures shall be used after TOE Delivery up to delivery to the end-user to maintain confidentiality and integrity of the TOE and of its manufacturing and test data (to prevent any possible copy, modification, retention, theft or unauthorised use).

This means that Phases after TOE Delivery up to the end of Phase 6 (refer to Section 2.1) must be protected appropriately.

4.2.4 Clarification of “Usage of Hardware Platform (OE.Plat-App)”

- 64 Regarding the cryptographic services this objective of the environment has to be clarified. The TOE supports cipher schemes as additional specific security functionality. If required the Smartcard Embedded Software shall use these cryptographic services of the TOE and their interface as specified. When key-dependent functions implemented in the Smartcard Embedded Software are just being executed, the Smartcard Embedded Software must provide protection against disclosure of confidential data (User Data) stored and/or processed in the TOE by using the methods described under “Inherent Information Leakage (T.Leak-Inherent)” and “Forced Information Leakage (T.Leak-Forced)”.
- 65 Regarding the area based access control this objective of the environment has to be clarified. For the separation of different applications the Smartcard Embedded Software (Operating System) may implement a memory management scheme based upon security mechanisms of the TOE.

- 66 For the separation of different applications the Smartcard Embedded Software may implement a memory management scheme based upon security mechanisms of the TOE as required by the security policy defined for the specific application context.

4.2.5 Clarification of “Treatment of User Data (OE.Resp-Appl)”

- 67 Regarding the cryptographic services this objective of the environment has to be clarified. By definition cipher or plain text data and cryptographic keys are User Data. The Smartcard Embedded Software shall treat these data appropriately, use only proper secret keys (chosen from a large key space) as input for the cryptographic function of the TOE and use keys and functions appropriately in order to ensure the strength of cryptographic operation.
- 68 This means that keys are treated as confidential as soon as they are generated. The keys must be unique with a very high probability, as well as cryptographically strong. For example, it must be ensured that it is beyond practicality to derive the private key from a public key if asymmetric algorithms are used. If keys are imported into the TOE and/or derived from other keys, quality and confidentiality must be maintained. This implies that appropriate key management has to be realised in the environment.
- 69 Regarding the area based access control this objective of the environment has to be clarified. The treatment of User Data is also required when a multi-application operating system is implemented as part of the Smartcard Embedded Software on the TOE. In this case the multi-application operating system should not disclose security relevant user data of one application to another application when it is processed or stored on the TOE.
- 70 The treatment of User Data is still required when a multi-application operating system is implemented as part of the Smartcard Embedded Software on the TOE. In this case the multi-application operating system should not disclose security relevant user data of one application to another application when it is processed or stored on the TOE.

5 IT SECURITY REQUIREMENTS

71 This chapter 5 IT Security Requirements contains the following sections:

5.1 TOE Security Requirements

5.2 Security Requirements for the Environment

5.1 TOE security requirements

5.1.1 TOE security functional requirements

72 In order to define the Security Functional Requirements the Part 2 of the Common Criteria was used. However, some Security Functional Requirements have been newly created and are not taken from Part 2 of the Common Criteria. Therefore, this Security Target is characterized by "Part 2 extended".

5.1.1.1 Malfunctions

73 The TOE shall meet the requirement "Limited fault tolerance (FRU_FLT.2)" as specified below.

FRU_FLT.2 Limited fault tolerance

Hierarchical to: FRU_FLT.1

FRU_FLT.2.1 The TSF shall ensure the operation of all the TOE's capabilities when the following failures occur: *exposure to operating conditions which are not detected according to the requirement Failure with preservation of secure state (FPT_FLS.1)*.

Dependencies: FPT_FLS.1 Failure with preservation of secure state

Refinement: The term "failure" above means "circumstances". The TOE prevents failures for the "circumstances" defined above.

74 The TOE shall meet the requirement "Failure with preservation of secure state (FPT_FLS.1)" as specified below.

FPT_FLS.1 Failure with preservation of secure state

Hierarchical to: No other components.

FPT_FLS.1.1 The TSF shall preserve a secure state when the following types of failures occur: *exposure to operating conditions which may not be tolerated according to the requirement Limited fault tolerance (FRU_FLT.2) and where therefore a malfunction could occur.*

Dependencies: ADV_SPM.1 informal TOE security policy model

Refinement: The term "failure" above also covers "circumstances". The TOE prevents failures for the "circumstances" defined above.

- 75 The TOE shall meet the requirement “TSF domain separation” state (FPT_SEP.1)” as specified below.
- FPT_SEP.1** TSF domain separation
- Hierarchical to: No other components.
- FPT_SEP.1.1 The TSF shall maintain a security domain for its own execution that protects it from interference and tampering by untrusted subjects.
- FPT_SEP.1.2 The TSF shall enforce separation between the security domains of subjects in the TSC.
- Dependencies: No dependencies.
- Refinement: Those parts of the TOE, which support the security functional requirements “Limited fault tolerance (FRU_FLT.2)” and “Failure with preservation of secure state (FPT_FLS.1)” shall be protected from interference of the Smartcard Embedded Software.

5.1.1.2 Abuse of Functionality

- 76 The TOE shall meet the requirement “Limited capabilities (FMT_LIM.1)” as specified below (Common Criteria Part 2 extended).
- FMT_LIM.1** Limited capabilities
- Hierarchical to: No other components.
- FMT_LIM.1.1 The TSF shall be designed in a manner that limits their capabilities so that in conjunction with “Limited availability (FMT_LIM.2)” the following policy is enforced: *Deploying Test Features after TOE Delivery does not allow User Data to be disclosed or manipulated, TSF data to be disclosed or manipulated, software to be reconstructed and no substantial information about construction of TSF to be gathered which may enable other attacks.*
- Dependencies: FMT_LIM.2 Limited availability.
- 77 The TOE shall meet the requirement “Limited availability (FMT_LIM.2)” as specified below (Common Criteria Part 2 extended).
- FMT_LIM.2** Limited availability
- Hierarchical to: No other components.
- FMT_LIM.2.1 The TSF shall be designed in a manner that limits their availability so that in conjunction with “Limited capabilities (FMT_LIM.1)” the following policy is enforced: *Deploying Test Features after TOE Delivery does not allow User Data to be disclosed or manipulated, TSF data to be disclosed or manipulated, software to be reconstructed and no substantial information about construction of TSF to be gathered which may enable other attacks.*
- Dependencies: FMT_LIM.1 Limited capabilities.

78 The TOE shall meet the requirement “Audit storage (FAU_SAS.1)” as specified below (Common Criteria Part 2 extended).

FAU_SAS.1 Audit storage

Hierarchical to: No other components.

FAU_SAS.1.1 The TSF shall provide test personnel before TOE Delivery with the capability to store the Initialisation Data and/or Prepersonalisation *Data and/or supplements of the Smartcard Embedded Software s* in the audit records.

Dependencies: No dependencies.

5.1.1.3 Physical Manipulation and Probing

79 The TOE shall meet the requirement “Resistance to physical attack (FPT_PHP.3)” as specified below.

FPT_PHP.3 Resistance to physical attack

Hierarchical to: No other components.

FPT_PHP.3.1 The TSF shall resist *physical manipulation and physical probing* ¹⁰ to the TSF ¹¹ by responding automatically such that the TSP is not violated.

Dependencies: No dependencies.

Refinement: The TOE will implement appropriate measures to continuously counter physical manipulation and physical probing. Due to the nature of these attacks (especially manipulation) the TOE can by no means detect attacks on all of its elements. Therefore, permanent protection against these attacks is required ensuring that the TSP could not be violated at any time. Hence, “automatic response” means here (i) assuming that there might be an attack at any time and (ii) countermeasures are provided at any time.

5.1.1.4 Leakage

80 The TOE shall meet the requirement “Basic internal transfer protection (FDP_ITT.1)” as specified below.

FDP_ITT.1 Basic internal transfer protection

Hierarchical to: No other components.

FDP_ITT.1.1 The TSF shall enforce the *Data Processing Policy* to prevent the *disclosure* of user data when it is transmitted between physically-separated parts of the TOE.

Dependencies: [FDP_ACC.1 Subset access control, or FDP_IFC.1 Subset information flow control]

Refinement: The different memories, the CPU and other functional units of the TOE (e.g. a cryptographic co-processor) are seen as physically-separated parts of the TOE.

- 81 The TOE shall meet the requirement “Basic internal TSF data transfer protection (FPT_ITT.1)” as specified below.
- FPT_ITT.1** Basic internal TSF data transfer protection
- Hierarchical to: No other components.
- FPT_ITT.1.1 The TSF shall protect TSF data from *disclosure* when it is transmitted between separate parts of the TOE.
- Dependencies: No dependencies.
- Refinement: The different memories, the CPU and other functional units of the TOE (e.g. a cryptographic co-processor) are seen as separated parts of the TOE.
- This requirement is equivalent to FDP_ITT.1 above but refers to TSF data instead of User Data. Therefore, it should be understood as to refer to the same *Data Processing Policy* defined under FDP_IFC.1 below.
- 82 The TOE shall meet the requirement “Subset information flow control (FDP_IFC.1)” as specified below:
- FDP_IFC.1** Subset information flow control
- Hierarchical to: No other components.
- FDP_IFC.1.1 The TSF shall enforce the Data Processing Policy on *all confidential data when they are processed or transferred by the TOE or by the Smartcard Embedded Software*.
- Dependencies: FDP_IFF.1 Simple security attributes
- Data Processing Policy** User Data and TSF data shall not be accessible from the TOE except when the Smartcard Embedded Software decides to communicate the User Data via an external interface. The protection shall be applied to confidential data only but without the distinction of attributes controlled by the Smartcard Embedded Software.

5.1.1.5 Random Numbers (RNG)

- 83 The TOE shall meet the requirement “Quality metric for random numbers (FCS_RND.1)” as specified below (Common Criteria Part 2 extended).
- FCS_RND.1** Quality metric for random numbers
- FCS_RND.1.1 The TSF shall provide a mechanism to generate random numbers that meet the “*standard*” level of DCSSI requirement regarding cryptography [*mécanismes cryptographiques*],
- Dependencies: No dependencies.

5.1.1.6 Memory access control

- 84 Usage of multiple applications in one Smartcard often requires separating code and data in order to prevent that one application can access code and/or data of another application. To support this the TOE provides Area based Memory Access Control.
- 85 The security service being provided is described in the Security Function Policy (SFP) **Memory Access Control Policy**. The security functional requirement “**Subset access control (FDP_ACC.1)**” requires that this policy is in place and defines the scope were it applies. The security functional requirement “**Security attribute based access control (FDP_ACF.1)**” defines addresses security attribute usage and characteristics of policies. It describes the rules for the function that implements the Security Function Policy (SFP) as identified in FDP_ACC.1. The decision whether an access is permitted or not is taken based upon attributes allocated to the software. The user software defines the attributes and memory areas. The corresponding permission control information is evaluated “on-the-fly” by the hardware so that access is granted/effective or denied/inoperable.
- 86 The security functional requirement “**Static attribute initialization (FMT_MSA.3)**” ensures that the default values of security attributes are appropriately either permissive or restrictive in nature. Alternative values can be specified by any subject provided that the **Memory Access Control Policy** allows that. This is described by the security functional requirement “**Management of security attributes (FMT_MSA.1)**”. The attributes are determined during TOE manufacturing (FMT_MSA.3) or set at run-time (FMT_MSA.1).
- 87 From TOE’s point of view the different roles in the user software can be distinguished according to the memory based access control. However the definition of the roles belongs to the user software.
- 88 The following Security Function Policy (SFP) **Memory Access Control Policy** is defined for the requirement “Security attribute based access control (FDP_ACF.1)”:

Memory Access Control Policy

The TOE shall control *read, write, delete, execute accesses of software running on data including code stored in memory areas.*

The TOE shall restrict the ability to define, to change or at least to finally accept the applied rules (as mentioned in FDP_ACF.1) to *software.*

- 89 The TOE shall meet the requirement “Subset access control (FDP_ACC.1)” as specified below.

FDP_ACC.1 Subset access control

Hierarchical to: No other components.

FDP_ACC.1.1 The TSF shall enforce the *Memory Access Control Policy on all subjects (software with user mode), all objects (data including code stored in memories) and all the operations defined in the Memory Access Control Policy.*

Subjects are software codes in User mode.

Object are data stored in ROM, RAM and FLASH memories.

Dependencies: FDP_ACF.1 Security attribute based access control

90 The TOE shall meet the requirement “Security attribute based access control (FDP_ACF.1)” as specified below.

FDP_ACF.1	Security attribute based access control
	The attributes are all the operations related to the data stored in memories, which are the <i>read</i> , <i>write</i> , <i>delete</i> and <i>execute</i> operations.
Hierarchical to:	No other components.
FDP_ACF.1.1	The TSF shall enforce the Memory Access Control Policy to objects based on the <i>memory area where the software is executed from and/or the memory area where the access is performed to and/or the operation to be performed</i> .
FDP_ACF.1.2	The TSF shall enforce the following rules to determine if an operation among controlled subjects and controlled objects is allowed: <i>evaluate the corresponding permission control information before the access so that accesses to be denied can not be utilised by the subject attempting to perform the operation</i> .
FDP_ACF.1.3	The TSF shall explicitly authorise access of subjects to objects based on the following additional rules: <i>none</i> .
FDP_ACF.1.4	The TSF shall explicitly deny access of subjects to objects based on the following additional rules: <i>none</i> .
Dependencies:	FDP_ACC.1 Subset access control FMT_MSA.3 Static attribute initialisation

91 The TOE shall meet the requirement “Static attribute initialisation (FMT_MSA.3)” as specified below.

FMT_MSA.3	Static attribute initialisation
Hierarchical to:	No other components.
FMT_MSA.3.1	The TSF shall enforce the <i>Memory Access Control Policy</i> to provide <i>well defined</i> default values for security attributes that are used to enforce the SFP.
FMT_MSA.3.2	The TSF shall allow <i>any subject (provided that the Memory Access Control Policy is enforced and the necessary access is therefore allowed)</i> to specify alternative initial values to override the default values when an object or information is created.
Dependencies:	FMT_MSA.1 Management of security attributes FMT_SMR.1 Security roles

- 92 The TOE shall meet the requirement “Management of security attributes (FMT_MSA.1)” as specified below:
- FMT_MSA.1** Management of security attributes
- Hierarchical to: No other components.
- FMT_MSA.1.1 The TSF shall enforce the *Memory Access Control Policy* to restrict the ability to *change default, modify or delete* the security attributes *permission control information to running at user mode*.
- Dependencies: [FDP_ACC.1 Subset access control or
FDP_IFC.1 Subset information flow control]
FMT_SMF.1 Specification of management functions
FMT_SMR.1 Security roles
- 93 The TOE shall meet the requirement “Specification of management functions (FMT_SMF.1)” as specified below:
- FMT_SMF.1** Specification of management functions
- Hierarchical to: No other components
- FMT_SMF.1.1 The TSF shall be capable of performing the following security management functions: *access the control registers of the MPU*.
- Dependencies: No dependencies

5.1.1.7 Cryptographic Support

- 94 FCS_COP.1 Cryptographic operation requires, a cryptographic operation to be performed in accordance with a specified algorithm and with a cryptographic key of specified sizes. The specified algorithm and cryptographic key sizes can be based on an assigned standard.
- 95 The following additional specific security functionality is implemented in the TOE:
- Triple Data Encryption Standard (3DES) with 112bit or 168bit key size,
 - Advanced Encryption Standard (AES) with 128bit, 192bit or 256bit key size,
 - Rivest-Shamir-Adleman (RSA) public key asymmetric cryptography, with key size from 1024bit up to 2048bit with a granularity of 2 bits (optional)
 - On-the-fly CRC operation

5.1.1.7.1 Triple-DES Operation

96 The Triple DES (3DES) operation of the TOE shall meet the requirement “Cryptographic operation (FCS_COP.1)” as specified below.

FCS_COP.1 Cryptographic operation

Hierarchical to: No other components.

FCS_COP.1.1 The TSF shall perform *encryption and decryption* in accordance with a specified cryptographic algorithm *Triple Data Encryption Standard (3DES)* with 112bit or 168bit key size that meet the following standards: *U.S. Department of Commerce / National Bureau of Standards, Data Encryption Standard (DES), FIPS PUB 46-3, 1999 October 25, keying option 2*

Dependencies: [FDP_ITC.1 Import of user data without security attributes or
FDP_ITC.2 Import of user data with security attributes, or
FCS_CKM.1 Cryptographic key generation]
FCS_CKM.4 Cryptographic key destruction
FMT_MSA.2 Secure security attributes

5.1.1.7.2 AES Operation

97 The AES operation of the TOE shall meet the requirement “Cryptographic operation (FCS_COP.1)” as specified below.

FCS_COP.1 Cryptographic operation

Hierarchical to: No other components.

FCS_COP.1.1 The TSF shall perform *encryption and decryption* in accordance with a specified cryptographic algorithm *Advanced Encryption Standard (AES)* with 128bit, 192bit or 256bit key size that meet the following standard: *U.S. Department of Commerce / National Bureau of Standards, Advanced Encryption Standard (AES), FIPS PUB 197, 2001 November 6*

Dependencies: [FDP_ITC.1 Import of user data without security attributes or
FDP_ITC.2 Import of user data with security attributes or
FCS_CKM.1 Cryptographic key generation]
FCS_CKM.4 Cryptographic key destruction
FMT_MSA.2 Secure security attributes

5.1.1.7.3 Rivest-Shamir-Adleman (RSA) operation (optional)

98 The RSA cryptographic library v3.8S of the TOE shall meet the requirement “Cryptographic operation (FCS_COP.1)” as specified below.

FCS_COP.1 Cryptographic operation

Hierarchical to: No other components

FCS_COP.1.1 The TSF shall perform *encryption and decryption* in accordance with a specified cryptographic algorithm *Rivest-Shamir-Adleman (RSA)* and cryptographic key sizes from 1024bit up to 2048bit with 2-bit granularity that meet the following standard: *ISO/IEC 9796-1, Annex A, sections A.4 and A.5, and Annex C.*

Dependencies: [FDP_ITC.1 Import of user data without security attributes or
FDP_ITC.2 Import of user data with security attributes, or
FCS_CKM.1 Cryptographic key generation]
FCS_CKM.4 Cryptographic key destruction
FMT_MSA.2 Secure security attributes

5.1.1.7.4 Rivest-Shamir-Adleman (RSA) key generation (optional)

99 The key generation for the RSA shall meet the requirement “Cryptographic key generation (FCS_CKM.1)”

FCS_CKM.1 Cryptographic key generation

Hierarchical to: No other components

FCS_CKM.1.1 The TSF shall generate cryptographic keys in accordance with a specified cryptographic key generation algorithm specified in *[ETSI]* and *[ALGO]* and specified cryptographic key sizes form 1024 up to 2048 bit with 2-bit granularity that meet the following standards: *ISO/IEC 9796-1, Annex A, sections A.4 and A.5, and Annex C.*

Dependencies: [FCS_CKM.2 Cryptographic key distribution or
FCS_COP.1 Cryptographic operation]
FCS_CKM.4 Cryptographic key destruction
FMT_MSA.2 Secure security attributes

5.1.1.7.5 On-the-fly CRC Operation

100 The On-the-fly CRC operation of the TOE shall meet the requirement “Cryptographic operation (FCS_COP.1)” as specified below.

FCS_COP.1 Cryptographic operation

Hierarchical to: No other components.

FCS_COP.1.1 The TSF shall perform *on-the-fly CRC operation* in accordance with a specified cryptographic algorithm *CRC-16* that meet the following standard: *CCITT V.41*

Dependencies: [FDP_ITC.1 Import of user data without security attributes or
FDP_ITC.2 Import of user data with security attributes]
FMT_MSA.2 Secure security attributes

5.1.1.7.6 Summary of Security Functional Requirements

Security Functional Requirements
Limited fault tolerance (FRU_FLT.2)
Failure with preservation of secure state (FPT_FLS.1)
TSF Domain Separation (FPT_SEP.1)
Audit storage (FAU_SAS.1 ¹)
Limited capabilities(FMT_LIM.1 ¹)
Limited availability (FMT_LIM.2 ¹)
Resistance to physical attack (FPT_PHP.3)
Basic internal transfer protection (FDP_ITT.1)
Basic internal TSF data transfer protection (FPT_ITT.1)
Subset information flow control (FDP_IFC.1)
Quality metric for random numbers (FCS_RND.1 ¹)

Table3. Security Functional Requirements defined in Smart Card IC Protection Profile

Note 1: Security Functional Requirement coming from *Protection Profile BSI-PP-0002 version 1.0*, not from *Common Criteria version 2.3 Part 2*

Security Functional Requirements
Subset access control (FDP_ACC.1)
Security attribute based access control (FDP_ACF.1)
Static attribute initialization (FMT_MSA.3)
Management of security attributes (FMT_MSA.1)
Specification of management functions (FMT_SMF.1)
Cryptographic operation (FCS_COP.1)
Cryptographic key generation (FCS_CKM.1) (optional)

Table4. Augmented Security Functional Requirements

5.1.2 TOE Assurance Requirements

101 The Security Target to be developed based upon this Protection Profile will be evaluated according to
Security Target evaluation (Class ASE)

102 The TOE Assurance Requirements for the evaluation of the TOE and its development and operating environment are those taken from the

Evaluation Assurance Level 4 (EAL4)

and augmented by the following components

ADV_IMP.2, ALC_DVS.2, AVA_MSU.3 and AVA_VLA.4.

103 corresponding to level "EAL4+".

104 All refinements from *Protection Profile BSI-PP-0002 version 1.0* for the assurance requirements (ACM_CAP.4, ADO_DEL.2, ADO_IGS.1, AGD_ADM.1, AGD_USR.1, and ATE_COV.2) have to be taken into consideration.

Development activities (Class ADV)

Functional Specification (Component ADV_FSP.2)
 Security Policy Modelling (Component ADV_SPM.1)
 High-Level Design (Component ADV_HLD.2)
 Low-Level Design (Component ADV_LLD.1)
Implementation Representation (Component ADV_IMP.2)
 Representation Correspondence (Component ADV_RCR.1)

Tests activities (Class ATE)

Coverage (Component ATE_COV.2)
 Depth (Component ATE_DPT.1)
 Functional Tests (Component ATE_FUN.1)
 Independent Testing (Component ATE_IND.2)

Delivery and operation activities (Class ADO)

Delivery (Component ADO_DEL.2)
 Installation, generation, and start-up (Component ADO_IGS.1)

Guidance documents activities (Class AGD)

Administrator Guidance (Component AGD_ADM.1)
 User guidance (Component AGD_USR.1)

Configuration management activities (Class ACM)

CM automation (Component ACM_AUT.1)
 CM Capabilities (Component ACM_CAP.4)
 CM Scope (Component ACM_SCP.2)

Life cycle support activities (Class ALC)

Development Security (Component ALC_DVS.2)
 Life Cycle Definition (Component ALC_LCD.1)
 Tools and Techniques (Component ALC_TAT.1)

Vulnerability assessment activities (Class AVA)

Misuse (Component AVA_MSU.3)
 Strength of TOE Security Functions (Component AVA_SOF.1)
Vulnerability Analysis (Component AVA_VLA.4)

5.2 Security Requirements for the Environment

5.2.1 Security Requirements for the IT-Environment

105 The security functional requirement “Cryptographic operation (FCS_COP.1)” met by TOE has the following dependencies:

[FDP_ITC.1 Import of user data without security attributes or
 FDP_ITC.2 Import of user data with security attributes or
 FCS_CKM.1 Cryptographic key generation],
 FCS_CKM.4 Cryptographic key destruction,
 FMT_MSA.2 Secure security attributes.

106 These requirements all address the appropriate management of cryptographic keys used by the specified cryptographic function. All requirements concerning key management shall be fulfilled by the environment since the Smartcard Embedded Software is designed for a specific application context and uses the cryptographic functions provided by the TOE.

5.2.1.1 Triple DES

107 The environment shall meet the requirement “Import of user data without security attributes (FDP_ITC.1)” or “Import of user data with security attributes (FDP_ITC.2)” or “Cryptographic key generation (FCS_CKM.1)” as specified below.

FDP_ITC.1 Import of user data without security attributes

Hierarchical to: No other components.

FDP_ITC.1.1 The TSF shall enforce the [assignment: access control SFP and/or information flow control SFP] when importing user data, controlled under the SFP, from outside of the TSC.

FDP_ITC.1.2 The TSF shall ignore any security attributes associated with the user data when imported from outside the TSC.

FDP_ITC.1.3 The TSF shall enforce the following rules when importing user data controlled under the SFP from outside the TSC: [assignment: additional importation control rules].

Dependencies: [FDP_ACC.1 Subset access control, or
 FDP_IFC.1 Subset information flow control]
 FMT_MSA.3 Static attribute initialisation

FDP_ITC.2 Import of user data with security attributes

Hierarchical to: No other components.

FDP_ITC.2.1 The TSF shall enforce the [assignment: access control SFP and/or information flow control SFP] when importing user data, controlled under the SFP, from outside of the TSC.

FDP_ITC.2.2 The TSF shall use the security attributes associated with the imported user data.

FDP_ITC.2.3 The TSF shall ensure that the protocol used provides for the unambiguous association between the security attributes and the user data received.

FDP_ITC.2.4 The TSF shall ensure that interpretation of the security attributes of the imported user data is as intended by the source of the user data.

FDP_ITC.2.5 The TSF shall enforce the following rules when importing user data controlled under the SFP from outside the TSC: [assignment: additional importation control rules]

Dependencies: [FDP_ACC.1 Subset access control, or
FDP_IFC.1 Subset information flow control]
[FTP_ITC.1 Inter-TSF trusted channel, or
FTP_TRP.1 Trusted path]
FPT_TDC.1 Inter-TSF basic TSF data consistency

FCS_CKM.1 Cryptographic keys generation

Hierarchical to: No other components.

FCS_CKM.1.1 The TSF shall generate cryptographic keys in accordance with a specified cryptographic key generation algorithm *Triple DES (3DES)* and specified cryptographic key sizes 112 bit or 168 bit that meet the following: *U.S. Department of Commerce / National Bureau of Standards Data Encryption Standard (DES), FIPS PUB 46-3, 1999 October 25, keying option 2.*

Dependencies: [FCS_CKM.2 Cryptographic key distribution or
FCS_COP.1 Cryptographic operation]
FCS_CKM.4 Cryptographic key destruction
FMT_MSA.2 Secure security attributes

108 The environment shall meet the requirement “Cryptographic key destruction (FCS_CKM.4)” as specified below.

FCS_CKM.4 Cryptographic key destruction

Hierarchical to: No other components.

FCS_CKM.4.1 The TSF shall destroy cryptographic keys in accordance with a specified cryptographic key destruction method [assignment: cryptographic key destruction method] that meets the following: [assignment: list of standards].

Dependencies: [FDP_ITC.1 Import of user data without security attributes or FDP_ITC.2
Import of user data with security attributes or
FCS_CKM.1 Cryptographic key generation]
FMT_MSA.2 Secure security attributes

109 The environment shall meet the requirement “Secure security attributes (FMT_MSA.2)” as specified below.

FMT_MSA.2 Secure security attributes

Hierarchical to: No other components.

FMT_MSA.2.1 The TSF shall ensure that only secure values are accepted for security attributes.

Dependencies: ADV_SPM.1 Informal TOE security policy model
[FDP_ACC.1 Subset access control or
FDP_IFC.1 Subset information flow control]
FMT_MSA.1 Management of security attributes
FMT_SMR.1 Security roles

5.2.1.2 AES

110 The environment shall meet the requirement “Import of user data without security attributes (FDP_ITC.1)” or “Import of user data with security attributes (FDP_ITC.2)” or “Cryptographic key generation (FCS_CKM.1)” as specified below.

FDP_ITC.1 Import of user data without security attributes

Hierarchical to: No other components.

FDP_ITC.1.1 The TSF shall enforce the [assignment: access control SFP and/or information flow control SFP] when importing user data, controlled under the SFP, from outside of the TSC.

FDP_ITC.1.2 The TSF shall ignore any security attributes associated with the user data when imported from outside the TSC.

FDP_ITC.1.3 The TSF shall enforce the following rules when importing user data controlled under the SFP from outside the TSC: [assignment: additional importation control rules].

Dependencies: [FDP_ITC.2 Import of user data with security attributes, or
FDP_ACC.1 Subset access control, or
FDP_IFC.1 Subset information flow control]
FMT_MSA.3 Static attribute initialisation

FDP_ITC.2 Import of user data with security attributes

Hierarchical to: No other components.

FDP_ITC.2.1 The TSF shall enforce the [assignment: access control SFP and/or information flow control SFP] when importing user data, controlled under the SFP, from outside of the TSC.

FDP_ITC.2.2 The TSF shall use the security attributes associated with the imported user data.

FDP_ITC.2.3 The TSF shall ensure that the protocol used provides for the unambiguous association between the security attributes and the user data received.

FDP_ITC.2.4 The TSF shall ensure that interpretation of the security attributes of the imported user data is as intended by the source of the user data.

FDP_ITC.2.5 The TSF shall enforce the following rules when importing user data controlled under the SFP from outside the TSC: [assignment: additional importation control rules]

Dependencies: [FDP_ACC.1 Subset access control, or
FDP_IFC.1 Subset information flow control]
[FTP_ITC.1 Inter-TSF trusted channel, or
FTP_TRP.1 Trusted path]
FPT_TDC.1 Inter-TSF basic TSF data consistency

FCS_CKM.1 Cryptographic keys generation

Hierarchical to: No other components.

FCS_CKM.1.1 The TSF shall generate cryptographic keys in accordance with a specified cryptographic algorithm *Advanced Encryption Standard (AES)* with 128bit, 192bit or 256bit key size that meet the following standard: *U.S. Department of Commerce / National Bureau of Standards, Advanced Encryption Standard (AES), FIPS PUB 197, 2001 November 6*

Dependencies: [FCS_CKM.2 Cryptographic key distribution or
FCS_COP.1 Cryptographic operation]
FCS_CKM.4 Cryptographic key destruction
FMT_MSA.2 Secure security attributes

111 The environment shall meet the requirement “Cryptographic key destruction (FCS_CKM.4)” as specified below.

FCS_CKM.4 Cryptographic key destruction

Hierarchical to: No other components.

FCS_CKM.4.1 The TSF shall destroy cryptographic keys in accordance with a specified cryptographic key destruction method [assignment: cryptographic key destruction method] that meets the following: [assignment: list of standards].

Dependencies: [FDP_ITC.1 Import of user data without security attributes or FDP_ITC.2
Import of user data with security attributes or
FCS_CKM.1 Cryptographic key generation]
FMT_MSA.2 Secure security attributes

112 The environment shall meet the requirement “Secure security attributes (FMT_MSA.2)” as specified below.

FMT_MSA.2 Secure security attributes

Hierarchical to: No other components.

FMT_MSA.2.1 The TSF shall ensure that only secure values are accepted for security attributes.

Dependencies: ADV_SPM.1 Informal TOE security policy model
[FDP_ACC.1 Subset access control or
FDP_IFC.1 Subset information flow control]
FMT_MSA.1 Management of security attributes
FMT_SMR.1 Security roles

5.2.1.3 RSA (optional)

113 The environment shall meet the requirement “Import of user data without security attributes (FDP_ITC.1)” or “Import of user data with security attributes (FDP_ITC.2)” or “Cryptographic key generation (FCS_CKM.1)” as specified below.

FDP_ITC.1 Import of user data without security attributes

Hierarchical to: No other components.

FDP_ITC.1.1 The TSF shall enforce the [assignment: access control SFP and/or information flow control SFP] when importing user data, controlled under the SFP, from outside of the TSC.

FDP_ITC.1.2 The TSF shall ignore any security attributes associated with the user data when imported from outside the TSC.

FDP_ITC.1.3 The TSF shall enforce the following rules when importing user data controlled under the SFP from outside the TSC: [assignment: additional importation control rules].

Dependencies: [FDP_ACC.1 Subset access control, or
FDP_IFC.1 Subset information flow control]
FMT_MSA.3 Static attribute initialisation

FDP_ITC.2 Import of user data with security attributes

Hierarchical to: No other components.

FDP_ITC.2.1 The TSF shall enforce the [assignment: access control SFP and/or information flow control SFP] when importing user data, controlled under the SFP, from outside of the TSC.

FDP_ITC.2.2 The TSF shall use the security attributes associated with the imported user data.

FDP_ITC.2.3 The TSF shall ensure that the protocol used provides for the unambiguous association between the security attributes and the user data received.

FDP_ITC.2.4 The TSF shall ensure that interpretation of the security attributes of the imported user data is as intended by the source of the user data.

FDP_ITC.2.5 The TSF shall enforce the following rules when importing user data controlled under the SFP from outside the TSC: [assignment: additional importation control rules]

Dependencies: [FDP_ACC.1 Subset access control, or
FDP_IFC.1 Subset information flow control]
[FTP_ITC.1 Inter-TSF trusted channel, or
FTP_TRP.1 Trusted path]
FPT_TDC.1 Inter-TSF basic TSF data consistency

FCS_CKM.1 Cryptographic keys generation

Hierarchical to: No other components.

FCS_CKM.1.1 The TSF shall generate cryptographic keys in accordance with a specified cryptographic key generation algorithm specified in [ETSI] and [ALGO] and specified cryptographic key sizes from 1024 up to 2048 bit with 2-bit granularity that meet the following standards: *ISO/IEC 9796-1, Annex A, sections A.4 and A.5, and Annex C.*

Dependencies: [FCS_CKM.2 Cryptographic key distribution or
FCS_COP.1 Cryptographic operation]
FCS_CKM.4 Cryptographic key destruction
FMT_MSA.2 Secure security attributes

114 The environment shall meet the requirement “Cryptographic key destruction (FCS_CKM.4)” as specified below.

FCS_CKM.4 Cryptographic key destruction

Hierarchical to: No other components.

FCS_CKM.4.1 The TSF shall destroy cryptographic keys in accordance with a specified cryptographic key destruction method [assignment: cryptographic key destruction method] that meets the following: [assignment: list of standards].

Dependencies: [FDP_ITC.1 Import of user data without security attributes or FDP_ITC.2 Import of user data with security attributes or FCS_CKM.1 Cryptographic key generation] FMT_MSA.2 Secure security attributes

115 The environment shall meet the requirement “Secure security attributes (FMT_MSA.2)” as specified below.

FMT_MSA.2 Secure security attributes

Hierarchical to: No other components.

FMT_MSA.2.1 The TSF shall ensure that only secure values are accepted for security attributes.

Dependencies: ADV_SPM.1 Informal TOE security policy model
[FDP_ACC.1 Subset access control or FDP_IFC.1 Subset information flow control]
FMT_MSA.1 Management of security attributes
FMT_SMR.1 Security roles

The security functional requirement “Cryptographic key generation (FCS_CKM.1)” met by the TOE has the following dependencies:

[FDP_CKM.2 Cryptographic key distribution or FCS_COP.1 Cryptographic operation],
FCS_CKM.4 Cryptographic key destruction,
FMT_MSA.2 Secure security attributes.

FCS_COP.1 is fulfilled by the TOE. FCS_CKM.4 and FMT_MSA.2 has to be fulfilled by the environment as described above for the RSA algorithm.

5.2.2 Security Requirements for the Non-IT-Environment

116 In the following security requirements for the Non-IT-Environment are defined. For the development of the Smartcard Embedded Software (in Phase 1) the requirement RE.Phase-1 is valid.

RE.Phase-1 Design and Implementation of the Smartcard Embedded Software

The developers shall design and implement the Smartcard Embedded Software in such way that it meets the requirements from the following documents:

- (i) S3FS9CI user’s manual,
- (ii) Security application note,
- (iii) TOE-application notes and
- (iv) findings of the TOE evaluation reports relevant for the Smartcard Embedded Software.

The developers shall implement the Smartcard Embedded Software in a way that it protects security relevant User Data (especially cryptographic keys) as required by the security needs of the specific application context.

- 117 The responsible parties for the Phases 4-6 are required to support the security of the TOE by appropriate measures:

RE.Process-Card Protection during Packaging, Finishing and Personalisation

The Card Manufacturer (after TOE Delivery up to the end of Phase 6) shall use adequate security measures to maintain confidentiality and integrity of the TOE and of its manufacturing and test data (to prevent any possible copy, modification, retention, theft or unauthorised use).

- 118 The Smartcard Embedded Software shall meet the requirements "Cipher Schemas (RE.Cipher)" as specified below.

RE.Cipher Cipher Schemas

The developers of Smartcard Embedded Software must not implement routines in a way, which may compromise keys when the routines are executed as part of the Smartcard Embedded Software. Performing functions, which access cryptographic keys could allow an attacker to misuse these functions to gather information about the key, which is used in the computation of the function.

Keys must be kept confidential as soon as they are generated. The keys must be unique with a very high probability, as well as cryptographically strong. For example, it must be ensured that it is not possible to derive the private key from a public key if asymmetric algorithms are used. If keys are imported into the TOE and/or derived from other keys, quality and confidentiality must be maintained. This implies that an appropriate key management has to be realised in the environment.

6 TOE SUMMARY SPECIFICATION

119 This chapter 6 TOE Summary Specification contains the following sections:

- 6.1 List of Security Functions
- 6.2 Relationship between security functions and functional requirements
- 6.3 Assurances Measures

6.1 List of Security Functions

SF1: Environmental Security violation recording and reaction

1) Detectors

120 These functions records in register the events notified by the detectors (refer to list below). The software configures the reaction in case of detection:

- The TOE is immediately reset when an event is detected.
- Or, a special function register bit is set.

List of detectors:

- Abnormal frequency Detector
- Abnormal voltage Detector
- Abnormal temperature Detector
- Light Detector
- Inner insulation removal Detector
- Active shield removal Detector
- Power Glitch Detector
- Fault Attack Detector

2) Filters

121 These filters are used for preventing noise, glitches and extremely high frequency in the external reset pad from causing undefined or unpredictable behavior of the chip.

- Reset Noise Filter

122 Security Function 1 covers the following Security Functional Requirements:

- 123 FPT_FLS.1: Failure with preservation of secure state. The detection thresholds of SF1 detectors are inside the operating range of the TOE. Therefore abnormal events/failures are detected before the secure state is compromised. This allows to take User's defined appropriate actions by software or to immediately RESET the TOE.
- 124 FRU_FLT.2: Limited fault tolerance. All operating signals (Clock, RESET and supply voltage) are filtered/regulated in order to prevent malfunction.
- 125 FPT_SEP.1: TSF domain separation. SF1 filters and detectors are implemented by the hardware. The filtering and detection cannot be affected or bypassed by Smartcard Embedded Software. The reaction to the detection can be configured by the software. The influence on security and the way how to

configure it is described in details in the *S3FS9CI User's Manual*. Therefore, FPT_SEP.1 is implemented by SF1.

- 126 FPT_PHP.3: Resistance to physical attacks. This requirement is achieved by security feature as the Active shield must be removed and bypassed in order to perform physical intrusive attacks

SF2: Access Control

1) Security registers access control

- 127 This security function manages access to the security control registers through access control security attributes.
- 128 The USER mode has another function, which is write-enable bit for security related registers. If user does not enable this bit in 128cycles after the reset, user cannot write security control registers any more.

2) Invalid address access

- 129 This function detects invalid address access occurrence. In case of an invalid address access is detected, an FIQ is evoked. The memory access rights are defined and configured through the control register MASCON and the Memory Protection Unit (MPU).
- 130 The MPU provide the Embedded Software the ability to define different access rights for different data and program memory areas. In case of an illegal memory access, an ABORT (Exception Handler) is generated, allowing to take dedicated and appropriate actions.

3) Access rights for the code executed in FLASH

- 131 This security function manages the code execution in FLASH, through access control security attributes. If an invalid access is detected, then a ABORT occurs.
- 132 Security Function 2 covers the following Security Functional Requirements:
- 133 FDP_ACC.1: Subset access control. The MPU allows defining different memory areas with different access rights.
- 134 FDP_ACF.1: Security attributes based access control. This is covered by User modes of the TOE.
- 135 FMT_MSA.3: Static attribute initialization. All Special Function Registers have DEFAULT values after Power on Reset.
- 136 FMT_MSA.1: Management of security attributes. This is achieved with the MPU feature.
- 137 FMT_SMF.1: Specification of management functions. This is achieved via access to Special Function Registers.
- 138 FPT_SEP.1: TSF domain separation. Security domains are maintained since accesses to the access-prohibited area are trapped by this access control function. Therefore, FPT_SEP.1 is implemented by this SF.

SF3: Non-reversibility of TEST and USER modes

1) Non-reversibility of TEST mode and USER mode

- 139 This function disables the TEST mode and enables the USER mode of the TOE. This function ensures the non-reversibility of the USER mode. This function is used once during the manufacturing process.

2) TEST mode communication protocol and data commands

- 140 This function is the proprietary protocol used to operate the chip in TEST mode. This function enforces the identification and authentication of the TEST administrator during the test phase of the manufacturing process. The Strength of this function (SOF) is: High

3) Functional Tests

- 141 During the manufacturing process, the operation of the TOE and the embedded software checksum are verified. This security function ensures the correct operation of the TOE security functions and the integrity of the embedded software.

4) Identification

- 142 During the TEST mode of manufacturing process, traceability data are written in the non-volatile memory of the TOE. Once the TOE is switched from TEST to USER mode, those traceability data are READ ONLY and cannot be modified anymore. This enables to identify and track the TOE during the rest of its life.
- 143 Security Function 3 covers the following Security Functional Requirements:
- 144 FAU_SAS.1: Audit Storage. This is fulfilled by the traceability/identification data written once and for all during the TEST mode of the manufacturing process.
- 145 FMT_LIM.1: Limited capabilities. TEST mode can be accessed only by the TEST administrator by supplying an authentication password through a proprietary protocol.
- 146 FMT_LIM.2: Limited availability. TEST mode can be accessed only by the TEST administrator by supplying an authentication password through a proprietary protocol.

SF4: Hardware countermeasures for unobservability

This Security Function is ensured by the combination of the following security features.

1) Static Address/Data scrambling for bus and memory

- 147 This function protects memory and address/data bus from probing attacks.

2) Dynamic Memory scrambling

- 148 This security function protects the memory contents of the TOE from data analysis on the stored data as well as on internally transmitted data. The algorithms used for encryption are proprietary. The RAM and the FLASH scrambling are dynamic key. RAM scrambling is performed automatically while FLASH scrambling is defined and managed by the embedded software.

3) Synthesizable processor core

- 149 The Central Processing Unit (CPU) of the TOE is synthesizable with glue logic, which makes reverse engineering and signal identification more difficult. Most sensitive hardware components such as buses are also hidden and implemented in deepest layers.

4) De-synchronization and signal-to-noise ratio reduction mechanisms

- 150 The TOE operations can be made asynchronous by using the Internal Variable Clock. They make a full range of intrusive (e.g. probing attacks) and non intrusive attacks (e.g. side-channel attacks) more complex and difficult.
- 151 Security Function 4 covers the following Security Functional Requirements:
- 152 FPT_PHP.3: Resistance to physical attacks. This requirement is achieved by bypassed in order to perform physical intrusive attacks and by security features 1) and 3) that makes the reverse-engineering of the TOE layout unpractical.
- 153 FDP_IFC.1: Subset information flow control. This requirement is covered by security feature 2).
- 154 FDP_ITT.1: Basic internal transfer protection. This requirement is achieved by the combination of the TOE security features 1) to 4) as it is unpractical to get access to internal signals and interpret them.
- 155 FPT_ITT.1: Basic internal TSF data transfer protection. This requirement is achieved by the combination of the TOE features 1) to 4) as it is unpractical to get access to internal signals and interpret them.

SF5: Cryptography**1) Triple Data Encryption Standard Engine**

156 This function is used for encrypting and decrypting data using the Triple DES symmetric algorithm with 112bit or 168bit key size.

2) Random Number Generator

157 This function is used for generating random numbers for security process in smart card applications and provides a mechanism to generate random numbers. It includes function:

- A Random Number Generator (RNG) library meets the “standard” level of DCSSI requirement

3) TORNADO™ RSA Cryptographic Library (optional)

158 This function assists in the acceleration of modulo exponentiations required in the RSA encryption/decryption algorithm.

159 TORNADO is a high speed modular multiplication coprocessor for RSA public key asymmetric cryptographic support. The TORNADO RSA Library is the software built on the TORNADO coprocessor that provides high level interface for RSA based algorithms.

The functions of the library included in the evaluation are:

- TND_RSA_SigSTD_Secure (RSA signature generation)
This function perform RSA signature with standard method (i.e. without CRT). It has several countermeasure implemented against power analysis attacks, including message blinding and exponent masking with random data. In addition some redundancy is added when reading the exponent in order to prevent fault attack.
- TND_RSA_SigCRT_Secure (RSA signature generation with CRT method)
This function perform RSA signature with CRT. It has several countermeasures implemented against power analysis attacks based on message blinding and exponent masking with random data. After computing the signature, verification is done on the result based on the public exponent that ensures that no fault occurred during computation (prevent fault attacks). This function uses two pre-computed values based on knowledge of the public exponent. These values can be calculated with the function TND_RSA_PrecomR.
- TND_RSA_SigCRT_Secure3 (RSA signature generation with CRT method)
This function perform RSA signature with CRT. It has several countermeasures implemented against power analysis attacks based on message blinding and exponent masking with random data. The CRT calculation is performed twice and the result is compared in order to ensure that no fault occurred during computation (prevent fault attacks). This function does not require the knowledge of the public exponent.
- TND_RSA_Verify (RSA signature verification)
- RSA_Key_Generation (RSA key generation)

The library supports operation size from 32 bits to 2048 bit by step of 2 bits. However, only key from 1024 bits size to 2048 bits are on the scope of this evaluation.

The functions TND_RSA_SigSTD_Secure, TND_RSA_SigCRT_Secure and TND_RSA_SigCRT_Secure3 have some countermeasure against SPA, DPA and DFA attacks.

4) AES (Advanced Encryption Standard)

160 This function supports the AES operation with 128 bit, 192bit and 256bit key size.

5) On-the-fly CRC

161 This function is used for on-the-fly CRC block for error detection during data access.

- 162 Security Function 5 covers the following Security Functional Requirements:
- 163 FCS_RND.1: Quality metric for random number. This requirement is ensured by the design of the random number generation algorithm.
- A Random Number Generator (RNG) library meets the “standard” level of DCSSI requirement.
- 164 FCS_COP.1: Cryptographic operation. This requirement is provided by the TOE.
- 165 FCS_CKM.1: Cryptographic key generation. This requirement is covered by the TOE for RSA key generation. (optional)

6.2 Relationship between security functions and functional requirements

166 The following table shows that the set of Security Functions covers all Functional Requirements:

SR SF	FAU_ SAS.1	FDP_ IFC.1	FDP_ ITT.1	FMT_ LIM.1	FMT_ LIM.2	FPT_ FLS.1	FPT_P HP.3	FPT_ ITT.1	FPT_ SEP.1	FRU_ FLT.2	FDP_ ACC.1	FDP_ ACF.1	FMT_ MSA.3	FMT_ MSA.1	FMT_ SMF.1	FCS_ RND.1	FCS_ COP.1	FCS_ CKM.1 (option al)
SF1						✓	✓		✓	✓								
SF2									✓		✓	✓	✓	✓	✓			
SF3	✓			✓	✓													
SF4		✓	✓				✓	✓										
SF5																✓	✓	✓

Table 5. Relationship between security function and functional requirement

6.3 Assurance Measures

Assurance Class	Assurance Family	Assurance Component	Assurance measure (document reference)
Security Target	ASE		Security Target
ACM: Configuration Management	ACM_AUT	1	Configuration Management Documentation (Class ACM)
	ACM_CAP	4	
	ACM_SCP	2	
ADO: Delivery and Operation	ADO_DEL	2	Delivery Procedures Documentation (Class ADO)
	ADO_IGS	1	Installation, generation and start-up Procedures (Class ADO)
ADV: Development	ADV_FSP	2	Functional Specification (Class ADV)
	ADV_HLD	2	High Level Design (Class ADV)
	ADV_LLD	1	Low Level Design (Class ADV)
	ADV_IMP	2	Implementation (Class ADV)
	ADV_RCR	1	All representation correspondence analyses are included in the relevant TOE representation documentation (FSP, HLD, LLD, IMP)
	ADV_SPM	1	Security Policy Model (Class ADV)
AGD: Guidance Documents	AGD_ADM	1	Guidance Documentation (Class AGD)
	AGD_USR	1	
ALC: Life Cycle Support	ALC_DVS	2	Development Security Procedures (Class ALC)
	ALC_LCD	1	Life Cycle Definition Documentation (Class ALC)
	ALC_TAT	1	Development Tool Documentation (Class ALC)
ATE: Tests	ATE_COV	2	Test Coverage Analysis (Class ATE)
	ATE_DPT	1	Test Depth Analysis (Class ATE) is described in Test Documentation (Class ATE)
	ATE_FUN	1	Test Documentation (Class ATE)
	ATE_IND	2	Independent Testing (Class ATE)
AVA: Vulnerability Assessment	AVA_MSU	3	Analysis of the Guidance Documentation (Class AVA)
	AVA_SOF	1	Strength of TOE SF Analysis (Class AVA)
	AVA_VLA	4	Vulnerability Analysis (Class AVA)

Table 6. Assurance measures table

7 PP CLAIMS

167 This chapter 7 PP Claims contains the following sections:

7.1 PP Reference

7.2 PP Tailoring

7.3 PP Auditions

7.1 PP reference

168 This security target conforms to the Smartcard IC Platform Protection Profile [BSI-PP-0002].

7.2 PP tailoring

169 The only tailoring made to the Smartcard IC Platform Protection Profile [BSI-PP-0002] is FCS_RND as described in section 5.1.1.5.

7.3 PP additions

170 Additional objectives and security functional requirements are explicitly mentioned in this Security Target:

171 One additional assumption A.Key-Function as described in section 3.2

172 One additional threat T.Mem-Access as described in section 3.3.3

173 One additional security policy P.Add-Functions as described in section ST, 3.4.1,

174 Two additional security objectives O.Add-Functions and O.Mem-Access as described in section 4.1.3,

175 Additional functional requirements FDP_ACC.1, FDP_ACF.1, FMT_MSA.1, FMT_MSA.3, FMT_SMF.1, FCS_COP.1, and FCS_CKM.1 (optional) as described in section 5.1.1

176 Additional functional requirements for the environment FDP_ITC.1, FDP_ITC.2, FCS_CKM.1, FCS_CKM.4 and FMT_MSA.2 as described in section 5.2.1.

177 One additional requirement for the non-IT environment RE.Cipher as described in section 5.2.2.

8 RATIONALE

178 This chapter 8 Rational contains the following sections:

8.1 Security Objectives Rationale

8.2 Security Requirements Rationale

8.3 Security Requirements are Mutually Supportive and Internally Consistent

8.1 Security Objectives Rationale

Assumption, Threat or Organisational Security Policy	Security Objective	Note
A.Plat-Appl	OE.Plat-Appl	(Phase 1)
A.Resp-Appl	OE.Resp-Appl	(Phase 1)
P.Process-TOE	OE.Process-TOE O.Identification	(Phase 2 - 3)
A.Process-Card	OE.Process-Card	Card (Phase 4 - 6)
T.Leak-Inherent	O.Leak- Inherent	
T.Phys_Probing	O.Phys-Probing	
T.Malfunction	O.Malfunction	
T.Phys-Manipulation	O.Phys-Manipulation	
T.Leak-Forced	O.Leak-Forced	
T.Abuse-Func	O.Abuse-Func	
T.RND	O.RND	
T.Mem-Access	O.Mem-Access	
P.Add-Functions	O.Add-Functions	
A.Key-Function	OE.Plat-Appl OE.Resp-Appl	

Table 7. Security Objectives versus Assumptions, Threats or Policies

179 The justification related to the assumption “Usage of Hardware Platform (A.Plat-Appl)” is as follows:

180 Since OE.Plat-Appl requires the Smartcard Embedded Software developer to implement those measures assumed in A.Plat-Appl, the assumption is covered by the objective.

181 The justification related to the assumption “Treatment of User Data (A.Resp-Appl)” is as follows:

182 Since OE.Resp-Appl requires the developer of the Smartcard Embedded Software to implement measures as assumed in A.Resp-Appl, the assumption is covered by the objective.

183 The justification related to the organisational security policy “Protection during TOE Development and Production (P.Process-TOE)” is as follows:

184 OE.Process-TOE requires the TOE Manufacturer to implement those measures assumed in P.Process-TOE. Therefore, the organisational security policy is covered by this objective, as far as organisational measures are concerned. The only issue not completely covered by these measures is the fact that the TOE has to support the possibility of unique identification. This is the content of

- O.Identification. Therefore, the organisational security policy is covered by OE.Process-Card and O.Identification.
- 185 The justification related to the assumption “Protection during Packaging, Finishing and Personalisation (A.Process-Card)” is as follows:
- 186 Since OE.Process-Card requires the Card Manufacturer to implement those measures assumed in A.Process-Card, the assumption is covered by this objective.
- 187 The justification related to the threats “Inherent Information Leakage (T.Leak-Inherent)”, “Physical Probing (T.Phys-Probing)”, “Malfunction due to Environmental Stress (T.Malfunction)”, “Physical Manipulation (T.Phys-Manipulation)”, “Forced Information Leakage (T.Leak-Forced)”, “Abuse of Functionality (T.Abuse-Func)” and “Deficiency of Random Numbers (T.RND)” is as follows:
- 188 For all threats the corresponding objectives are stated in a way, which directly corresponds to the description of the threat. It is clear from the description of each objective, that the corresponding threat is removed if the objective is valid. More specifically, in every case the ability to use the attack method successfully is countered, if the objective holds. The justification related to the threat “Memory Access Violation (T.Mem-Access)” is as follows:
- 189 According to O.Mem-Access the TOE must enforce the partitioning of memory areas so that access of software to memory areas is controlled. Any restrictions are to be defined by the Smartcard Embedded Software. Thereby security violations caused by accidental or deliberate access to restricted data (which may include code) can be prevented (refer to T.Mem-Access). The threat T.Mem-Access is therefore removed if the objective is met.
- 190 The clarification of “Usage of Hardware Platform (OE.Plat-App)” makes clear that it is up to the Smartcard Embedded Software to implement the memory management scheme by appropriately administrating the TSF. This is also expressed both in T.Mem-Access and O.Mem-Access. The TOE shall provide access control functions as a means to be used by the Smartcard Embedded Software. This is further emphasised by the clarification of “Treatment of User Data (OE.Resp-App)” which reminds that the Smartcard Embedded Software must not undermine the restrictions it defines. Therefore, the clarifications contribute to the coverage of the threat T.Mem-Access.
- 191 The justification related to the security objective “Additional Specific Security Functionality (O.Add-Functions)” is as follows: Since O.Add-Functions requires the TOE to implement exactly the same specific security functionality as required by P.Add-Functions, the organisational security policy is covered by the objective.
- 192 Nevertheless the security objectives O.Leak-Inherent, O.Phys-Probing, O.Malfunction, O.Phys-Manipulation and O.Leak-Forced define how to implement the specific security functionality required by P.Add-Functions. (Note that these objectives support that the specific security functionality is provided in a secure way as expected from P.Add-Functions.) Especially O.Leak-Inherent and O.Leak-Forced refer to the protection of confidential data (User Data or TSF data) in general. User Data are also processed by the specific security functionality required by P.Add-Functions.
- 193 Compared to Smartcard IC Platform Protection Profile a clarification has been made for the security objective “Usage of Hardware Platform (OE.Plat-App)”: If required the Smartcard Embedded Software shall use these cryptographic services of the TOE and their interface as specified. In addition, the Smartcard Embedded Software must implement functions which perform operations on keys (if any) in such a manner that they do not disclose information about confidential data. The non disclosure due to leakage A.Key-Function attacks is included in this objective OE.Plat-App. This addition ensures that the assumption A.Plat-App is still covered by the objective OE.Plat-App although additional functions are being supported according to O.Add-Functions.
- 194 Compared to Smartcard IC Platform Protection Profile a clarification has been made for the security objective “Treatment of User Data (OE.Resp-App)”: By definition cipher or plain text data and cryptographic keys are User Data. So, the Smartcard Embedded Software will protect such data if required and use keys and functions appropriately in order to ensure the strength of cryptographic operation. Quality and confidentiality must be maintained for keys that are imported and/or derived from other keys. This implies that appropriate key management has to be realised in the environment.

That is expressed by the assumption A.Key – Function which is covered from OE.Resp–Appl. These measures make sure that the assumption A.Resp–Appl is still covered by the security objective OE.Resp–Appl although additional functions are being supported according to P.Add-Functions.

- 195 The justification of the additional policy and the additional assumption show that they do not contradict to the rationale already given in the Protection Profile for the assumptions, policy and threats defined there.

8.2 Security Requirements Rationale

8.2.1 Rationale for the security functional requirements

Objective	TOE Security Functional Requirements	Security Requirements for the environment
O.Leak-Inherent	<ul style="list-style-type: none"> FDP_ITT.1 "Basic internal transfer protection" FPT_ITT.1 "Basic internal TSF data transfer protection" FDP_IFC.1 "Subset information flow control" 	RE.Phase-1 "Design and Implementation of the Smartcard Embedded Software"
O.Phys-Probing	<ul style="list-style-type: none"> FPT_PHP.3 "Resistance to physical attack" 	RE.Phase-1 "Design and Implementation of the Smartcard Embedded Software"
O.Malfunction	<ul style="list-style-type: none"> FRU_FLT.2 "Limited fault tolerance" FPT_FLS.1 "Failure with preservation of secure state" FPT_SEP.1 "TSF domain separation" 	
O.Phys-Manipulation	<ul style="list-style-type: none"> FPT_PHP.3 "Resistance to physical attack" 	RE.Phase-1 "Design and Implementation of the Smartcard Embedded Software" (e. g. by implementing FDP_SDI.1 Stored data integrity monitoring)
O.Leak-Forced	<p>All requirements listed for O.Leak-Inherent</p> <ul style="list-style-type: none"> FDP_ITT.1, FPT_ITT.1, FDP_IFC.1 plus those listed for O.Malfunction and O.Phys-Manipulation FRU_FLT.2, FPT_FLS.1, FPT_SEP.1, FPT_PHP.3 	RE.Phase-1 "Design and Implementation of the Smartcard Embedded Software"

Objective	TOE Security Functional Requirements	Security Requirements for the environment
O.Abuse-Func	<ul style="list-style-type: none"> FMT_LIM.1 "Limited capabilities" FMT_LIM.2 "Limited availability" plus those for O.Leak-Inherent, O.Phys-Probing, O.Malfunction, O.Phys-Manipulation, O.Leak-Forced <ul style="list-style-type: none"> FDP_ITT.1, FPT_ITT.1, FDP_IFC.1, FPT_PHP.3, FRU_FLT.2, FPT_FLS.1, FPT_SEP.1 	
O.Identification	- FAU_SAS.1 "Audit storage"	
O.RND	<ul style="list-style-type: none"> FCS_RND.1 "Quality metric for random numbers" plus those for O.Leak-Inherent, O.Phys-Probing, O.Malfunction, O.Phys-manipulation, O.Leak-Forced FDP_ITT.1, FPT_ITT.1, FDP_IFC.1, FPT_PHP.3, FRU_FLT.2, FPT_FLS.1, FPT_SEP.1 	RE.Phase-1 "Design and Implementation of the Smartcard Embedded Software" (e. g. by implementing FPT_AMT.1 "Abstract machine testing")
OE.Process-TOE	<ul style="list-style-type: none"> FAU_SAS.1 "Audit storage" 	Assurance Components: Delivery (ADO_DEL); Installation, generation, and startup (ADO_IGS) (using Administrator Guidance (AGD_ADM), User guidance (AGD_USR)); CM automation (ACM_AUT); CM Capabilities (ACM_CAP); CM Scope (ACM_SCP); Development Security (ALC_DVS); Life Cycle Definition (ALC_LCD); Tools and Techniques (ALC_TAT)
OE.Process-Card		RE.Process-Card possibly supported by RE.Phase-1

Objective	TOE Security Functional Requirements	Security Requirements for the environment
O.Add-Functions	<ul style="list-style-type: none"> • FCS_COP.1 „Cryptographic operation“ • FCS_CKM.1 (RSA) (optional) 	<ul style="list-style-type: none"> • RE.Phase-1 “Design and Implementation of the Smartcard Embedded Software” with RE.Cipher
OE.Plat-Appl		RE.Phase-1 “Design and Implementation of the Smartcard Embedded Software” RE.Cipher
OE.Resp-Appl		RE.Phase-1 “Design and Implementation of the Smartcard Embedded Software” RE.Cipher [FDP_ITC.1 or FDP_ITC.2] (for 3DES and RSA (optional)) FCS_CKM.1 (for 3DES and optionally for RSA (optional)) FCS_CKM.4 (for 3DES and RSA (optional)) FMT_MSA.2 (for 3DES and RSA (optional))
O.Mem-Access	<ul style="list-style-type: none"> • FDP_ACC.1 “Subset access control” • FDP_ACF.1 “Security attribute based access control” • FMT_MSA.3 “Static attribute initialisation” • FMT_MSA.1 “Management of security attributes” • FMT_SMF.1 “Specification of Management Functions” 	RE.Phase-1 “Design and Implementation of the Smartcard Embedded Software”

Table 8. Security Objectives versus Assumptions, Threats or Policies

- 196 The justification related to the security objective “Protection against Inherent Information Leakage (O.Leak-Inherent)” is as follows:
- 197 The refinements of the security functional requirements FPT_ITT.1 and FDP_ITT.1 together with the policy statement in FDP_IFC.1 explicitly require the prevention of disclosure of secret data (TSF data as well as User Data) when transmitted between separate parts of the TOE or while being processed. This includes that attackers cannot reveal such data by measurements of emanations, power consumption or other behaviour of the TOE while data are transmitted between or processed by TOE parts.
- 198 Of course this has also to be supported by the Smartcard Embedded Software. For example timing attacks were possible if the processing time of algorithms implemented in the software would depend on the content of secret variables. The requirement RE.Phase-1 makes sure that this is avoided.
- 199 The justification related to the security objective “Protection against Physical Probing (O.Phys-Probing)” is as follows:
- 200 The scenario of physical probing as described for this objective is explicitly included in the assignment chosen for the physical tampering scenarios in FPT_PHP.3. Therefore, it is clear that this security functional requirement supports the objective.

- 201 It is possible that the TOE needs additional support by the Smartcard Embedded Software (e. g. to send data over certain buses only with appropriate precautions). If necessary this support is provided according to RE.Phase-1. Together with this FPT_PHP.3 is suitable to meet the objective.
- 202 The justification related to the security objective “Protection against Malfunctions (O.Malfunction)” is as follows:
- 203 The definition of this objective shows that it covers a situation, where malfunction of the TOE might be caused by the operating conditions of the TOE (while direct manipulation of the TOE is covered O.Phys-Manipulation). There are two possibilities in this situation: Either the operating conditions are inside of the tolerated range or at least one of them is outside of this range. The second case is covered by FPT_FLS.1, because it states that a secure state is preserved in this case. The first case is covered by FRU_FLT.2 because it states that the TOE operates correctly under normal (tolerated) conditions. To support this, FPT_SEP.1 the functions implementing FRU_FLT.2 and FPT_FLS.1 must work independently so that their operation can not affected by the Smartcard Embedded Software (refer to the refinement). Therefore, there is no possible instance of conditions under O.Malfunction, which is not covered.
- 204 The justification related to the security objective “Protection against Physical Manipulation (O.Phys-Manipulation)” is as follows:
- 205 The scenario of physical manipulation as described for this objective is explicitly included in the assignment chosen for the physical tampering scenarios in FPT_PHP.3. Therefore, it is clear that this security functional requirement supports the objective.
- 206 It is possible that the TOE needs additional support by the Embedded Software (for instance by implementing FDP_SDI.1 to check data integrity with the help of appropriate checksums). This support is provided according to RE.Phase-1. Together with this FPT_PHP.3 is suitable to meet the objective.
- 207 The justification related to the security objective “Protection against Forced Information Leakage (O.Leak-Forced)” is as follows:
- 208 This objective is directed against attacks, where an attacker wants to force an information leakage, which would not occur under normal conditions. In order to achieve this the attacker has to combine a first attack step, which modifies the behaviour of the TOE (either by exposing it to extreme operating conditions or by directly manipulating it) with a second attack step measuring and analysing some output produced by the TOE. The first step is prevented by the same measures which support O.Malfunction and O.Phys-Manipulation, respectively. The requirements covering O.Leak-Inherent also support O.Leak-Forced because they prevent the attacker from being successful if he tries the second step directly.
- 209 The justification related to the security objective “Protection against Abuse of Functionality (O.Abuse-Func)” is as follows:
- 210 This objective states that abuse of functions (especially provided by the IC Dedicated Test Software, for instance in order to read secret data) must not be possible in Phase 7 of the life-cycle. There are two possibilities to achieve this: (i) They cannot be used by an attacker (i. e. its availability is limited) or (ii) using them would not be of relevant use for an attacker (i. e. its capabilities are limited) since the functions are designed in a specific way. The first possibility is specified by FMT_LIM.2 and the second one by FMT_LIM.1. Since these requirements are combined to support the policy, which is suitable to fulfil O.Abuse-Func, both security functional requirements together are suitable to meet the objective.
- 211 Other security functional requirements which prevent attackers from circumventing the functions implementing these two security functional requirements (for instance by manipulating the hardware) also support the objective.
- 212 It was chosen to define FMT_LIM.1 and FMT_LIM.2 explicitly (not using Part 2 of the Common Criteria) for the following reason: Though taking components from the Common Criteria catalogue makes it easier to recognise functions, any selection from Part 2 of the Common Criteria would have

made it harder for the reader to understand the special situation meant here. As a consequence, the statement of explicit security functional requirements was chosen to provide more clarity.

- 213 The justification related to the security objective “TOE Identification (O.Identification)” is as follows:
- 214 Obviously the operations for FAU_SAS.1 are chosen in a way that they require the TOE to provide the functionality needed for O.Identification. The Initialisation Data (or parts of them) are used for TOE identification.
- 215 It was chosen to define FAU_SAS.1 explicitly (not using a given security functional requirement from Part 2 of the Common Criteria) for the following reason: The security functional requirement FAU_GEN.1 in Part 2 of the CC requires the TOE to generate the audit data and gives details on the content of the audit records (for instance data and time). The possibility to use the functions in order to store security relevant data which are generated outside of the TOE, is not covered by the family FAU_GEN or by other families in Part 2. Moreover, the TOE cannot add time information to the records, because it has no real time clock. Therefore, the new family FAU_SAS was defined for this situation.
- 216 The justification related to the security objective “Random Numbers (O.RND)” is as follows:
- 217 FCS_RND.1 requires the TOE to provide random numbers of good quality.
- 218 Other security functional requirements, which prevent physical manipulation and malfunction of the TOE (see the corresponding objectives listed in the table) support this objective because they prevent attackers from manipulating or otherwise affecting the random number generator.
- 219 Random numbers are often used by the Smartcard Embedded Software to generate cryptographic keys for internal use. Therefore, the TOE must prevent the unauthorised disclosure of random numbers. Other security functional requirements which prevent inherent leakage attacks, probing and forced leakage attacks ensure the confidentiality of the random numbers provided by the TOE.
- 220 Depending on the functionality of specific TOEs the Smartcard Embedded Software will have to support the objective by providing runtime-tests of the random number generator. Together, these requirements allow the TOE to provide cryptographically good random numbers and to ensure that no information about the produced random numbers is available to an attacker.
- 221 It was chosen to define FCS_RND.1 explicitly, because Part 2 of the Common Criteria does not contain generic security functional requirements for Random Number generation. (Note that there are security functional requirements in Part 2 of the Common Criteria, which refer to random numbers. However, they define requirements only for the authentication context, which is only one of the possible applications of random numbers.)
- 222 The justification related to the security objective “Usage of Hardware Platform (OE.Plat-Appl)” is as follows:
- 223 RE.Phase-1 requires the Smartcard Embedded Software developer to design and implement the software in a way, which is suitable to meet OE.Plat-Appl.
- 224 The justification related to the security objective “Treatment of User Data (OE.Resp-Appl)” is as follows:
- 225 RE.Phase-1 requires the developer of the Smartcard Embedded Software to design and implement the software in a way, which is suitable to meet OE.Resp-Appl.
- 226 The justification related to the security objective “Protection during TOE Development and Production (OE.Process-TOE)” is as follows:
- 227 The objective OE.Process-TOE has mainly to be fulfilled by organisational and other measures, which the TOE Manufacturer has to implement. These measures are a subset of those measures, which are examined during the evaluation of the assurance requirements of the classes ACM, AGD, ALC and ADO. The technical capability of the TOE to store Initialisation Data and/or Pre-personalisation Data is provided according to FAU_SAS.1. Together these security requirements are suitable to meet the objective.

- 228 The justification related to the security objective “Protection during Packaging, Finishing and Personalisation (OE.Process-Card)” is as follows:
- 229 RE.Process-Card requires the Card Manufacturer to use adequate measures to fulfil OE.Process-Card. Depending on the security needs of the application, the Smartcard Embedded Software may have to support this for instance by using appropriate authentication mechanisms for personalisation functions. Therefore, RE.Phase-1 may support RE.Process-Card in fulfilling the objective in addition.
- 230 The justification related to the security objective “Area based Memory Access Control (O.Mem-Access)” is as follows:
- 231 The security functional requirement “Subset access control (FDP_ACC.1)” with the related Security Function Policy (SFP) “Memory Access Control Policy” exactly require the implementation of an area based memory access control, which is a requirement from O.Mem-Access. Therefore, FDP_ACC.1 with its SFP is suitable to meet the security objective.
- 232 Nevertheless, the developer of the Smartcard Embedded Software must ensure that the additional functions are used as specified and that the User Data processed by these functions are protected as defined for the application context. These issues are addressed by the requirement RE.Phase-1. The TOE only provides the tool to implement the policy defined in the context of the application.
- 233 The justification related to the security objective “Additional Specific Security Functionality (O.Add-Functions)” is as follows:
- 234 The security functional requirement(s) “Cryptographic operation (FCS_COP.1)” exactly require those functions to be implemented which are demanded by O.Add-Functions. FCS_CKM.1 supports the generation of RSA keys needed for this cryptographic operations (optional). Therefore, FCS_COP.1 and FCS_CKM.1 are suitable to meet the security objective.
- 235 Nevertheless, the developer of the Smartcard Embedded Software must ensure that the additional functions are used as specified and that the User Data processed by these functions are protected as defined for the application context. These issues are addressed by the requirement RE.Phase-1 and more specific by the security functional requirements
- 236 [FDP_ITC.1 Import of user data without security attributes or
FDP_ITC.2 Import of user data with security attributes or
FCS_CKM.1 Cryptographic key generation],
FCS_CKM.4 Cryptographic key destruction,
FMT_MSA.2 Secure security attributes.
- 237 to be met by the environment.
- 238 All these requirements have to be fulfilled to support OE.Resp-Appl for the 3DES algorithms. For the RSA algorithm FCS_CKM.1 is optional, since it is fulfilled by the TOE. Nevertheless the user can generate keys externally additionally
- 239 The security functional requirements required to meet the security objectives O.Leak-Inherent, O.Phys-Probing, O.Malfunction, O.Phys-Manipulation and O.Leak-Forced define how to implement the specific security functionality. However, key-dependent functions could be implemented in the Smartcard Embedded Software. In this case RE.Cipher requires that these functions ensure that confidential data (User Data) can not be disclosed while they are just being processed by the Smartcard Embedded Software. Therefore, with respect to the Smartcard Embedded Software the issues addressed by the objectives just mentioned are addressed by the requirement RE.Cipher.
- 240 The usage of cryptographic algorithms requires using appropriate keys. Otherwise they do not provide security. The requirement RE.Cipher addresses these specific issues since cryptographic keys and other data are provided by the Smartcard Embedded Software. RE.Cipher requires that keys must be kept confidential. They must be unique with a very high probability, cryptographically strong etc. If keys are imported into the TOE (usually after TOE Delivery), it must be ensured that quality and confidentiality is maintained. Therefore, with respect to the environment the issues addressed (i) by the objectives just mentioned and (ii) implicitly by O.Add-Functions are addressed by the requirement RE.Cipher.

- 241 All these requirements have to be fulfilled to support OE.Resp-Appl for the 3DES algorithms. For the RSA algorithm FCS_CKM.1 is optional, since it is fulfilled by the TOE. Nevertheless the user can generate keys externally additionally.
- 242 In this ST the objectives for the environment OE.Plat-Appl and OE.Resp-Appl have been clarified. The requirement for the environment Re.Cipher has been introduced to cover the objectives OE.Plat-Appl and OE.Resp-Appl (in addition to O.Add-Functions). The Smartcard Embedded Software defines the use of the cryptographic functions FCS_COP.1 provided by the TOE. RE.Phase-1, which is assigned to OE. Resp-Appl in the Smartcard IC Platform Protection Profile, requires the Smartcard Embedded Software Developer to design and implement the software that it protects security relevant User Data (especially cryptographic keys). The requirements for the environment FDP_ITC.1, FDP_ITC.2, FCS_CKM.1, FCS_CKM.4, and FMT_MSA.2 support an appropriate key management. These security requirements are suitable to meet OE.Resp-Appl.
- 243 The justification of the security objective and the additional requirements (both for the TOE and its environment) show that they do not contradict to the rationale already given in the Protection Profile for the assumptions, policy and threats defined there.

8.2.2 Dependencies of security functional requirements

Security Functional Requirement	Dependencies	Fulfilled by security requirements
FRU_FLT.2	FPT_FLS.1	Yes
FPT_FLS.1	ADV_SPM.1	Yes (Part of EAL4)
FPT_SEP.1	None	No dependency
FMT_LIM.1	FMT_LIM.2	Yes
FMT_LIM.2	FMT_LIM.1	Yes
FAU_SAS.1	None	No dependency
FPT_PHP.3	None	No dependency
FDP_ITT.1	FDP_ACC.1 or FDP_IFC.1	Yes
FDP_IFC.1	FDP_IFF.1	See discussion below
FPT_ITT.1	None	No dependency
FCS_RND.1	None	No dependency

Security Functional Requirement	Dependencies	Fulfilled by security requirements
FCS_COP.1 (3DES)	FCS_CKM.1	Yes (by the environment)
	FDP_ITC.1 or FDP_ITC.2 (if not FCS_CKM.1) FCS_CKM.4 FMT_MSA.2	Yes (by the environment)
FCS_COP.1 (RSA) (optional)	FCS_CKM.1	Yes (additionally it can be fulfilled by the environment)
	FDP_ITC.1 or FDP_ITC.2 (if not FCS_CKM.1) FCS_CKM.4 FMT_MSA.2	Yes (by the environment)
FDP_ACC.1	FDP_ACF.1	Yes
FDP_ACF.1	FDP_ACC.1 FMT_MSA.3	Yes Yes
FMT_MSA.3	FMT_MSA.1 FMT_SMR.1	Yes See discussion below
FMT_MSA.1	FDP_ACC.1 or FDP_IFC.1 FMT_SMR.1 FMT_SMF.1	Yes See discussion below Yes
FMT_SMF.1	None	No dependency
FCS_CKM.1 (optional)	FCS_COP.1 or FCS_CKM.2 FCS_CKM.4 FMT_MSA.2	Yes See discussion below See discussion below

Table 9. Dependencies of the Security Functional Requirements

- 244 Part 2 of the Common Criteria defines the dependency of FDP_IFC.1 (information flow control policy statement) on FDP_IFF.1 (Simple security attributes). The specification of FDP_IFF.1 would not capture the nature of the security functional requirement nor add any detail. As stated in the *Data Processing Policy* referred to in FDP_IFC.1 there are no attributes necessary. The security functional requirement for the TOE is sufficiently described using FDP_ITT.1 and its *Data Processing Policy* (FDP_IFC.1). Therefore the dependency is considered satisfied.
- 245 As Table 8 shows, all other dependencies are fulfilled by security requirements defined in this Protection Profile. The dependencies FCS_CKM.1, FCS_CKM.4 (optional) and FMT_MSA.2 (optional) must be covered from the environment (the smartcard embedded software).
- 246 Concerning the requirement FPT_FLS.1 (Failure with preservation of secure state) the TSF shall preserve a secure state when the following types of failures occur: exposure to operating conditions which may not be tolerated according to the requirement FRU_FLT.2 (Limited fault tolerance) and where therefore a malfunction could occur. Here the term "failure" above also covers "circumstances". The TOE prevents failures for the "circumstances" defined above. In this context the detection thresholds of detectors are inside the operating range of the TOE. Therefore abnormal events/failures are detected before the secure state is compromised. This allows to take user defined appropriate actions by software or to immediately RESET the TOE (also cf. FPT_FLS.1 related information in the TSP model).
- 247 The dependency FMT_SMR.1 introduced by the two components FMT_MSA.1 and FMT_MSA.3 is considered to be satisfied because the access control specified for the intended TOE is not role-based

but enforced for each subject. Therefore, there is no need to identify roles in form of a security functional requirement FMT_SMR.1.

8.2.3 Rationale for the Assurance Requirements and the Strength of Function Level

- 248 The assurance level EAL4 and the augmentation with the requirements ADV_IMP.2, ALC_DVS.2, AVA_MSU.3, and AVA_VLA.4 were chosen in order to meet assurance expectations explained in the following paragraphs.
- 249 An assurance level of EAL4 is required for this type of TOE since it is intended to defend against highly sophisticated attacks without a protected environment. This evaluation assurance level was selected since it provides even formal evidence on the conducted vulnerability assessment. In order to provide a meaningful level of assurance that the TOE provides an adequate level of defense against such attacks, the evaluators have access to all information regarding the TOE including the low level design and source code.
- 250 The rationale for the strength of function level from the Smartcard IC Platform Protection Profile is used as the level is not changed.

ADV_IMP.2 Sufficiency of security measures

- 251 This assurance component is a higher hierarchical component to EAL 4 (which only requires ADV_IMP.1). It is important for a smartcard IC that the evaluation includes the implementation representation of the entire TSF and determines whether the functional requirements in the Security Target are addressed by the representation of the TSF. IC dedicated software source code and IC hardware drawings are examples of TSF implementation representation.
- 252 The implementation representation is used to express the notion of the least abstract representation of the TSF, specifically the one that is used to create the TSF itself without further design refinement.
- 253 ADV_IMP.2 has dependencies with ADV_LLD.1 "Descriptive Low-Level design", ADV_RCR.1 "Informal correspondence demonstration", ALC_TAT.1 "Well defined development tools". These assurance components are included in EAL4, then these dependencies are satisfied.

ALC_DVS.2 Sufficiency of security measures

- 254 Development security is concerned with physical, procedural, personnel and other technical measures that may be used in the development environment to protect the TOE.
- 255 In the particular case of a Smartcard Integrated Circuit the TOE is developed and produced within a complex and distributed industrial process which must especially be protected. Details about the implementation, (e.g. from design, test and development tools as well as Initialization Data) may make such attacks easier. Therefore, in the case of a Smartcard Integrated Circuit, maintaining the confidentiality of the design is very important.
- 256 This assurance component is a higher hierarchical component to EAL4 (which only requires ALC_DVS.1). ALC_DVS.2 has no dependencies.

AVA_MSU.3 Analysis and testing for insecure states

- 257 The user guidance must be correct and sufficient to ensure that the TOE can be used in a secure way and that vulnerabilities are not introduced.
- 258 This component is included to ensure that misleading, unreasonable and conflicting guidance is absent from the guidance documentation, and that secure procedures for all modes of operation have been addressed. Insecure states should be easy to detect. In this component, an analysis of the guidance documentation provided by the developer is validated and confirmed through testing by the evaluator to provide additional assurance.
- 259 This assurance component is a higher hierarchical component to EAL4 (which only requires AVA_MSU.2).

260 AVA_MSU.3 has dependencies with ADO_IGS.1 "Installation, generation, and start-up procedures", ADV_FSP.1 "Informal functional specification", AGD_ADM.1 "Administrator guidance" and AGD_USR.1 "User guidance". The dependencies are satisfied in EAL4.

AVA_VLA.4 Highly resistant

- 261 Due to the intended use of the TOE, it must be shown to be highly resistant to penetration attacks. This assurance requirement is achieved by the AVA_VLA.4 component.
- 262 Independent vulnerability analysis is based on highly detailed technical information and goes beyond the vulnerabilities identified by the developer. The main intent of the evaluator analysis is to determine that the TOE is resistant to penetration attacks performed by an attacker possessing a high attack potential.
- 263 AVA_VLA.4 has dependencies with ADV_FSP.1 "Informal functional specification", ADV_HLD.2 "Security enforcing high-level design", ADV_LLD.1 "Descriptive low-level design", ADV_IMP.1 "Subset of the implementation of the TSF", AGD_ADM.1 "Administrator Guidance", AGD_USR.1 "User Guidance".
- 264 All these dependencies are satisfied by EAL4.

8.3 Security Requirements are Mutually Supportive and Internally Consistent

- 265 The discussion of security functional requirements and assurance components in the preceding sections has shown that mutual support and consistency are given for both groups of requirements. The arguments given for the fact that the assurance components are adequate for the functionality of the TOE also shows that the security functional requirements and assurance requirements support each other and that there are no inconsistencies between these groups.
- 266 The security functional requirement FPT_PHP.3 makes it harder to manipulate User Data and TSF Data. This protects the primary assets identified in Section 3.1 and other security features or functions which use these data.
- 267 Though a manipulation of the TOE (refer to FPT_PHP.3) is not of great value for an attacker in itself, it can be an important step in order to threaten the primary assets identified in Section 3.1. Therefore, the security functional requirement FPT_PHP.3 is not only required to meet the security objective O.Phys-Manipulation. Instead it protects other security features or functions of both the TOE and the Smartcard Embedded Software from being bypassed, deactivated or changed. In particular this may pertain to the security features or functions being specified using FDP_ITT.1, FPT_ITT.1, FPT_FLS.1, FMT_LIM.2, FCS_RND.1, and those implemented in the Smartcard Embedded Software.
- 268 A malfunction of TSF (refer to FRU_FLT.2 and FPT_FLS.1) can be an important step in order to threaten the primary assets identified in Section 3.1. Therefore, the security functional requirements FRU_FLT.2 and FPT_FLS.1 are not only required to meet the security objective O.Malfunction. Instead they protect other security features or functions of both the TOE and the Smartcard Embedded Software from being bypassed, deactivated or changed. In particular this pertains to the security features or functions being specified using FDP_ITT.1, FPT_ITT.1, FMT_LIM.1, FMT_LIM.2, FCS_RND.1, and those implemented in the Smartcard Embedded Software.
- 269 In a forced leakage attack the methods described in "Malfunction due to Environmental Stress" (refer to T.Malfunction) and/or "Physical Manipulation" (refer to T.Phys-Manipulation) are used to cause leakage from signals which normally do not contain significant information about secrets. Therefore, in order to avert the disclosure of primary assets identified in Section 3.1 it is important that the security functional requirements averting leakage (FDP_ITT.1, FPT_ITT.1) and those against malfunction (FRU_FLT.2 and FPT_FLS.1) and physical manipulation (FPT_PHP.3) are effective and bind well. The security features and functions against malfunction ensure correct operation of other security functions (refer to above) and help to avert forced leakage themselves in other attack scenarios. The security features and functions against physical manipulation make it harder to manipulate the other security functions (refer to above).

- 270 Physical probing (refer to FPT_PHP.3) shall directly avert the disclosure of primary assets identified in Section 3.1. In addition, physical probing can be an important step in other attack scenarios if the corresponding security features or functions use secret data. For instance the security functional requirement FMT_LIM.2 may use passwords. Therefore, the security functional requirement FPT_PHP.3 (against probing) help to protect other security features or functions including those being implemented in the Smartcard Embedded Software. Details depend on the implementation.
- 271 Leakage (refer to FDP_ITT.1, FPT_ITT.1) shall directly avert the disclosure of primary assets identified in Section 3.1. In addition, inherent leakage and forced leakage (refer to above) can be an important step in other attack scenarios if the corresponding security features or functions use secret data. For instance the security functional requirement FMT_LIM.2 may use passwords. Therefore, the security functional requirements FDP_ITT.1 and FPT_ITT.1 help to protect other security features or functions implemented in the Smartcard Embedded Software (FDP_ITT.1) or provided by the TOE (FPT_ITT.1). Details depend on the implementation.
- 272 According to the assumption Usage of Hardware Platform (A.Plat-Appl) the Smartcard Embedded Software will correctly use the functions provided by the TOE. Hereby the User Data are treated as required to meet the requirements defined for the specific application context (refer to Treatment of User Data (A.Resp-Appl)). However, the TOE may implement additional functions. This can be a risk if their interface can not completely be controlled by the Smartcard Embedded Software. Therefore, the security functional requirements FMT_LIM.1 and FMT_LIM.2 are very important. They ensure that appropriate control is applied to the interface of these functions (limited availability) and that these functions, if being usable, provide limited capabilities only.
- 273 The combination of the security functional requirements FMT_LIM.1 and FMT_LIM.2 ensures that (especially after TOE Delivery) these additional functions can not be abused by an attacker to (i) disclose or manipulate User Data, (ii) to manipulate (explore, bypass, deactivate or change) security features or functions of the TOE or of the Smartcard Embedded Software or (iii) to enable an attack. Hereby the binding between these two security functional requirements is very important:
- 274 The security functional requirement Limited Capabilities (FMT_LIM.1) must close gaps which could be left by the control being applied to the function's interface (Limited Availability (FMT_LIM.2)). Note that the security feature or function which limits the availability can be bypassed, deactivated or changed by physical manipulation or a malfunction caused by an attacker. Therefore, if Limited Availability (FMT_LIM.2) is vulnerable, it is important to limit the capabilities of the functions in order to limit the possible benefit for an attacker.
- 275 The security functional requirement Limited Availability (FMT_LIM.2) must close gaps which could result from the fact that the function's kernel in principle would allow to perform attacks. The TOE must limit the availability of functions which potentially provide the capability to disclose or manipulate User Data, to manipulate security features or functions of the TOE or of the Smartcard Embedded Software or to enable an attack. Therefore, if an attacker could benefit from using such functions, it is important to limit their availability so that an attacker is not able to use them.
- 276 No perfect solution to limit the capabilities (FMT_LIM.1) is required if the limited availability (FMT_LIM.2) alone can prevent the abuse of functions. No perfect solution to limit the availability (FMT_LIM.2) is required if the limited capabilities (FMT_LIM.1) alone can prevent the abuse of functions. Therefore, it is correct that both requirements are defined in a way that they together provide sufficient security.
- 277 It is important to avert malfunctions of TSF and of security functions implemented in the Smartcard Embedded Software (refer to above). There are two security functional requirements which ensure that malfunctions can not be caused by exposing the TOE to environmental stress. First it must be ensured that the TOE operates correctly within some limits (Limited fault tolerance (FRU_FLT.2)). Second the TOE must prevent its operation outside these limits (Failure with preservation of secure state (FPT_FLS.1)). Both security functional requirements together prevent malfunctions. The two functional requirements must define the "limits". Otherwise there could be some range of operating conditions which is not covered so that malfunctions may occur. Consequently, the security functional requirements Limited fault tolerance (FRU_FLT.2) and Failure with preservation of secure state (FPT_FLS.1) are defined in a way that they together provide sufficient security.

- 278 The security functional requirements required to meet the security objectives O.Leak-Inherent, O.Phys-Probing, O.Malfunction, O.Phys-Manipulation and O.Leak-Forced also protect the cryptographic algorithms implemented according to the security functional requirement FCS_COP.1. Therefore, these security functional requirements support the secure implementation and operation of FCS_COP.1.
- 279 The security functional requirements required to meet the security objectives O.Leak-Inherent, O.Phys-Probing, O.Malfunction, O.Phys-Manipulation and O.Leak-Forced also protect the area based memory access control function implemented according to the security functional requirement described in the security functional requirement FDP_ACC.1 with reference to the Memory Access Control Policy and details given in FDP_ACF.1. Therefore, those security functional requirements support the secure implementation and operation of FDP_ACF.1 with its dependent security functional requirements.

9 ANNEX

Glossary

Application Software (AS)

Is the part of ES in charge of the Application of the Smart Card IC.

Basic Software (BS)

Is the part of ES in charge of the generic functions of the Smart Card IC such as Operating System, general routines and Interpreters.

DAC

Discretionary Access Control

Dedicated Software (DS)

Is defined as the part of ES provided to test the component and/or to manage specific functions of the component.

Embedded Software (ES)

Is defined as the software embedded in the Smart Card Integrated Circuit. The ES may be in any part of the non-volatile memories of the Smart Card IC.

Embedded software developer

Institution (or its agent) responsible for the Smart Card embedded software development and the specification of pre-personalization requirements.

Initialization

Is the process to write specific information in the NVM during IC manufacturing and testing (phase 3) as well as to execute security protection procedures by the IC manufacturer. The information could contain protection codes or cryptographic keys.

Initialization Data

Specific information written during manufacturing or testing of the TOE

Integrated Circuit (IC)

Electronic component(s) designed to perform processing and/or memory functions.

IC designer

Institution (or its agent) responsible for the IC development.

IC manufacturer

Institution (or its agent) responsible for the IC manufacturing, testing, and pre-personalization.

IC packaging manufacturer

Institution (or its agent) responsible for the IC packaging and testing.

Personaliser

Institution (or its agent) responsible for the Smart Card personalization and final testing.

Personalization data

Specific information in the NVM during personalization phase

RBAC

Role-Based Access Control

Security Information

Secret data, initialization data or control parameters for protection system

Smart Card

A credit sized plastic card, which has a non-volatile memory and a processing unit embedded within it.

Smart Card Issuer

Institution (or its agent) responsible for the Smart Card product delivery to the Smart Card end-user.

Smart Card product manufacturer

Institution (or its agent) responsible for the Smart Card product finishing process and testing.

Smart Card Application Software (AS)

Is the part of ES dedicated to the applications

Abbreviations**CC**

Common Criteria

EAL

Evaluation Assurance Level

IT

Information Technology

PP

Protection Profile

SF

Security Function

SOF

Strength of Function

ST

Security Target

TOE

Target of Evaluation

TSC

TSF Scope of Control

TSF

TOE Security Functions

TSFI

TSF Interface

TSP

TOE Security Policy

Literature

[ALGO] *Federal Gazette No 58, Notification in accordance with the Electronic Signatures Act and the Electronic Signatures Ordinance (overview of suitable algorithms), Federal Network Agency for Electricity, Gas, Telecommunications, Post and Railway, 2006-01-02*

[ETSI] *Electronic Signatures and Infrastructures (ESI); Algorithms and Parameters for Secure Electronic Signatures; Part 1: Hash functions and asymmetric algorithms, ETSI TS 102 176-1 V1.2.1 (2005-07)*

[Mécanismes cryptographiques] *Règles et recommandations concernant le choix et le dimensionnement des mécanismes cryptographiques de niveau de robustesse standard, 1.10 du 19 décembre 2006, reference: 2741/SGDN/DCSSI/SDS/Crypto*